

KTM POWERPARTS **INFORMATION**

LED INDICATOR KIT



64114937044

05.2019
3.213.954



KTM Sportmotorcycle GmbH
5230 Mattighofen, Austria
www.ktm.com



3 DEUTSCH

Wir freuen uns, dass Sie sich für dieses Produkt entschieden haben.

Unser hochwertiges Qualitätsprodukt ist rennerprobt und wurde speziell für sportliche Herausforderungen entwickelt. Eine korrekte Montage des Produktes ist unerlässlich, um ein Maximum an Sicherheit und Funktionalität gewährleisten zu können. Bitte befolgen Sie daher die Montageanleitung oder wenden Sie sich an Ihren autorisierten Fachhändler.

Für falsche Montage oder Verwendung dieses Produktes kann der (Quasi-)Hersteller bzw. Lieferant nicht zur Verantwortung gezogen werden.
Vielen Dank.

16 ENGLISH

Thank you for choosing this product.

Our high quality product has been tested under racing conditions and was developed specifically for use in sports activities. Correct installation of the product is essential to ensure that a maximum degree of safety and functionality is achieved. Therefore, please follow the installation instructions or contact your authorized dealer.

The (quasi) manufacturer or supplier cannot be held responsible for products that are incorrectly mounted or inappropriately used.
Thank you.

29 ITALIANO

Grazie per aver scelto questo prodotto.

Questo nostro prodotto di pregiata qualità è collaudato nelle competizioni ed è stato sviluppato specificamente per gare sportive. Il montaggio corretto del prodotto è fondamentale per garantirne la massima sicurezza e funzionalità. Rispetti quindi le istruzioni di montaggio o rivolgerti al proprio concessionario autorizzato.

Il produttore (detentore del marchio)/fornitore non può essere considerato responsabile per un montaggio o impiego errato del presente prodotto.
Vi ringraziamo per l'attenzione!

42 FRANÇAIS

Merci d'avoir porté votre choix sur ce produit.

Notre produit de haute qualité est éprouvé pour les compétitions et a été conçu spécialement pour un usage sportif. Un montage approprié du produit est indispensable pour garantir une sécurité et une fonctionnalité maximales du véhicule. C'est pourquoi nous vous invitons à suivre scrupuleusement le manuel de montage ou à vous adresser à votre revendeur agréé.

En cas de montage ou d'utilisation non conformes de ce produit, le (quasi) constructeur ou le fournisseur déclinent toute responsabilité.
Merci !

55 ESPAÑOL

Le agradecemos que se haya decidido por este producto.

Este producto de alta calidad está probado para la competición y se ha desarrollado específicamente para las exigencias de este deporte. Para poder garantizar los máximos niveles de seguridad y funcionalidad, es imprescindible que el producto se monte correctamente. Por este motivo, es muy importante que siga las instrucciones del manual de montaje o que se ponga en contacto con su concesionario autorizado.

El (cuasi) fabricante y el proveedor de este producto no se harán responsables del montaje y el uso incorrectos.
¡Muchas gracias!

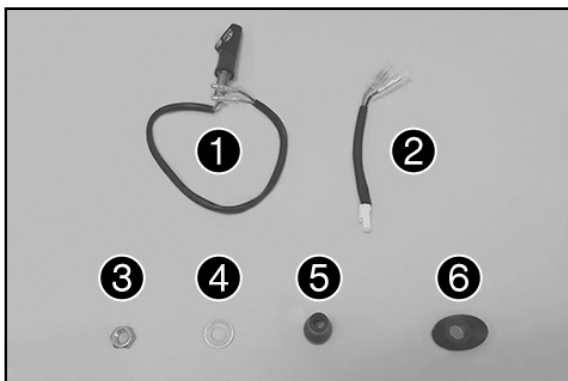

Lieferumfang

- 1x Blinker ❶
- 1x Widerstand ❷
- 1x Mutter ❸
- 1x Scheibe ❹
- 1x Schutzkappe ❺
- 1x Blinkeradapter ❻

Blinker vorn 790 Duke

Montage

- Zündung ausschalten.
- Schrauben ❷ entfernen.

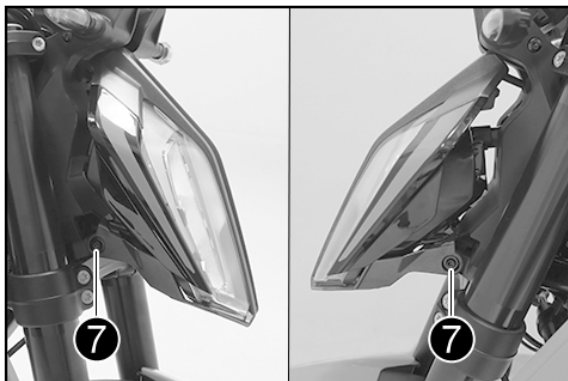

- Einstellschraube ❸ komplett herausdrehen.

HINWEIS

Die Einstellschraube ist durch eine Kugelkopfhalterung an der Scheinwerfermaske befestigt.
Die Einstellschraube nicht aus der Kugelkopfhalterung ziehen.

- Scheinwerfermaske leicht nach vorn schwenken und Stecker ❹ abstecken.
- Scheinwerfer abnehmen.

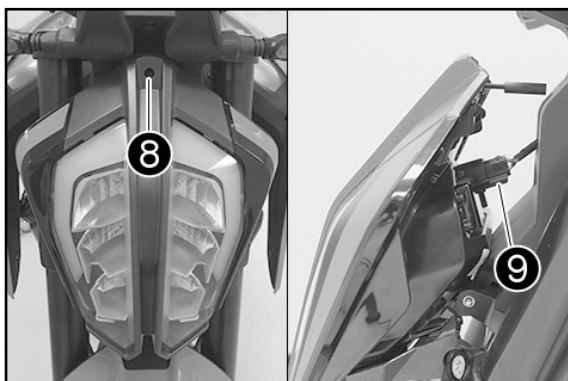

- Schrauben ❿ entfernen.
- Schrauben ⓫ entfernen.
- Schrauben ⓬ entfernen.

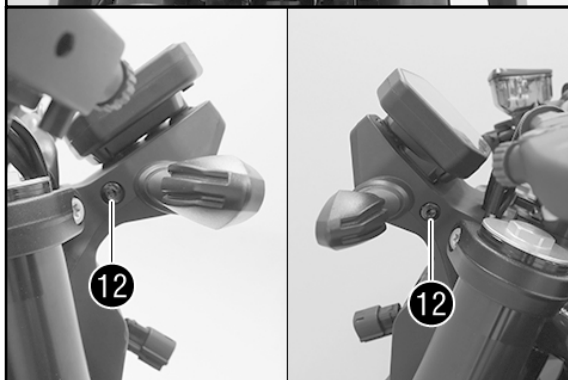
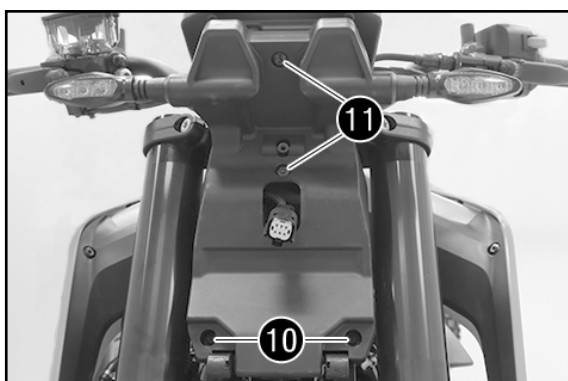

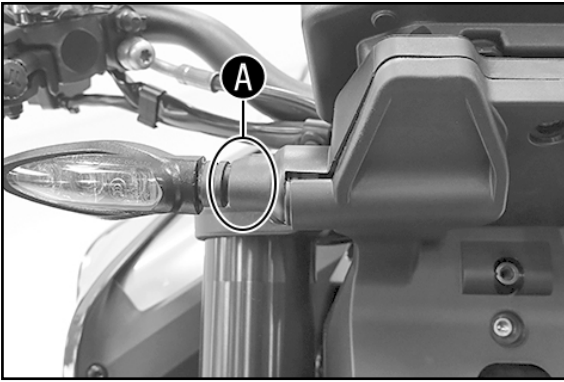

- Blinker im Bereich **A** greifen und vorsichtig entgegen der Fahrtrichtung drücken.

✓ Die Abdeckung löst sich wie im Bild ersichtlich.

- Arbeitsschritt auf der gegenüberliegenden Seite wiederholen.
- Abdeckung entfernen.

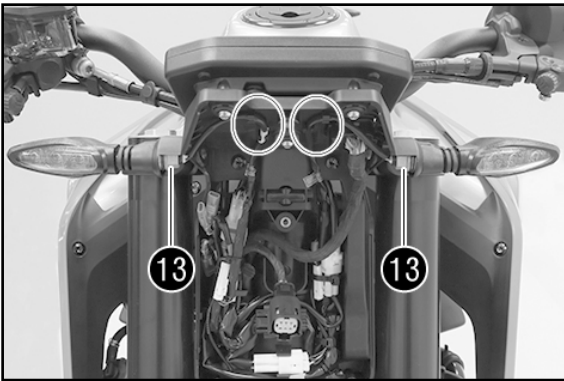

- Muttern **13** komplett vom Gewinde lösen.
- Blinkerkabel aus den Halterungen oben entfernen.

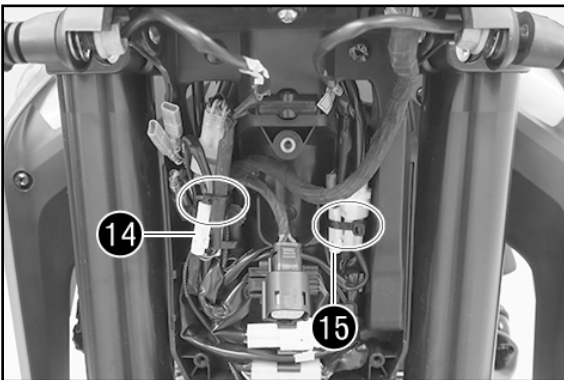

- Kabelbinder entfernen.
- Blinker-Steckerverbindungen rechts **14** und links **15** trennen.
- Blinker mit Muttern und Scheiben entfernen.

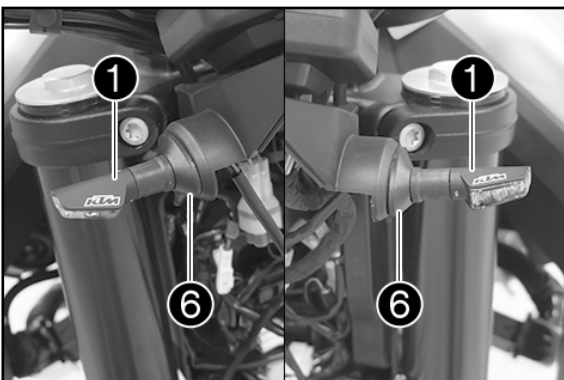

- Blinkeradapter **6** (Lieferumfang) am Blinker **1** (Lieferumfang) vormontieren.
- Blinker **1** (Lieferumfang) einfädeln und mit Blinkeradapter **6** positionieren.

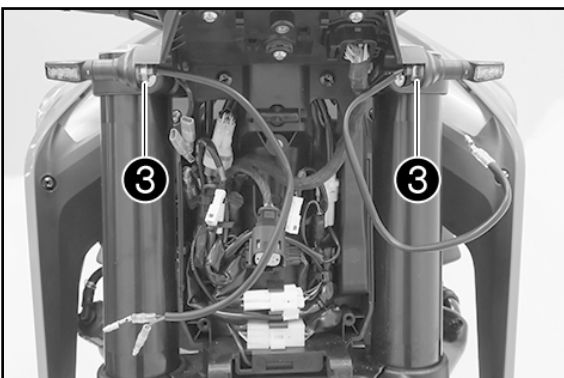

- Muttern **3** mit Scheiben **4** (alles Lieferumfang) montieren und festziehen.

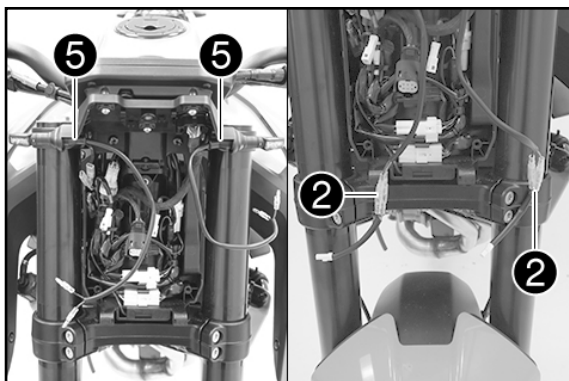

- Schutzkappen 5 (Lieferumfang) montieren.
- Widerstände 2 (Lieferumfang) entsprechend der Farben anstecken.

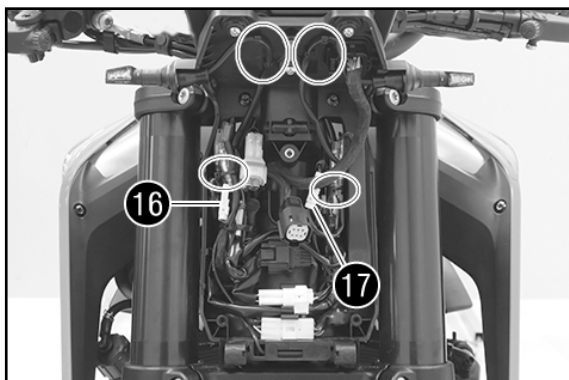

- Blinker-Steckerverbindungen 16 und 17 zusammenstecken.
- Blinkerkabel in den Halterungen oben montieren.
- Alle Kabel spannungsfrei verlegen und mit Kabelbinder sichern.

! VORSICHT

Sicher stellen, dass das Kabel nicht geknickt oder geklemmt werden kann!

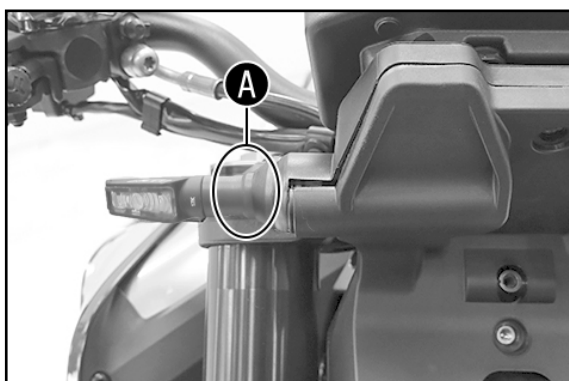

- Abdeckung positionieren, dabei die Steckerverbindung des Scheinwerfers durch die Öffnung führen.
- Blinker im Bereich A greifen und vorsichtig entgegen der Fahrtrichtung drücken, gleichzeitig die Abdeckung festdrücken.

✓ Abdeckung rastet mit einem hörbaren Klicken ein.

- Arbeitsschritt auf der gegenüberliegenden Seite wiederholen.

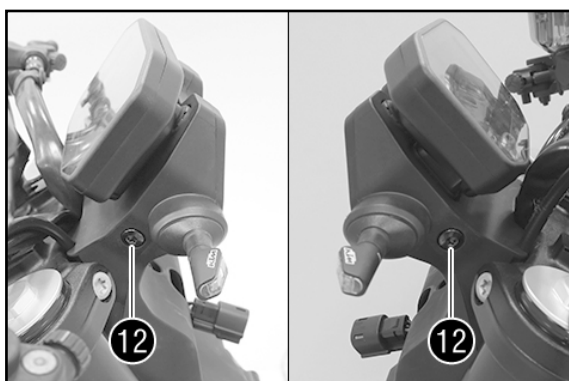

- Schrauben 12 montieren und mit 5 Nm festziehen.
- Schrauben 11 montieren und mit 5 Nm festziehen.
- Schrauben 10 montieren und mit 2 Nm festziehen.

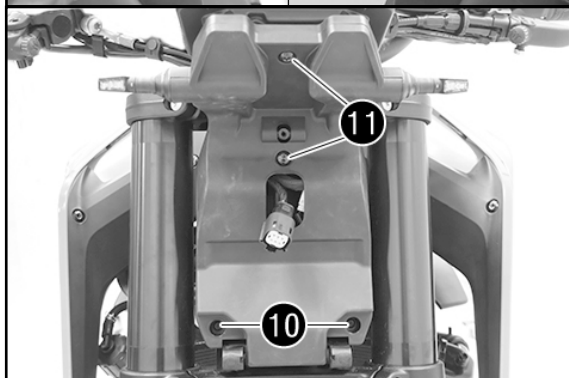

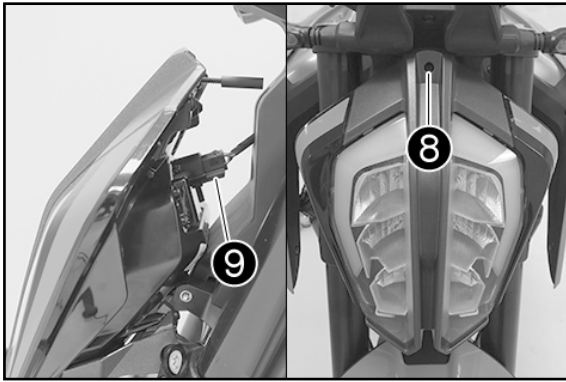

- Stecker 9 anstecken.
- Scheinwerfermaske positionieren.
- Einstellschraube 8 montieren.

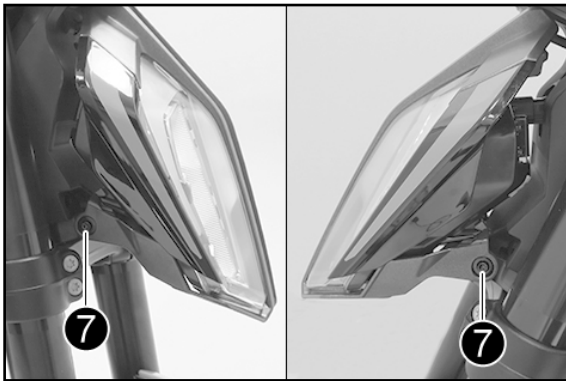

- Schrauben 7 montieren und mit 2 Nm festziehen.

Nacharbeit

- Scheinwerfereinstellung kontrollieren (s. Bedienungsanleitung).
- Leuchtweite des Scheinwerfers einstellen (s. Bedienungsanleitung).
- Funktion der Beleuchtung kontrollieren.

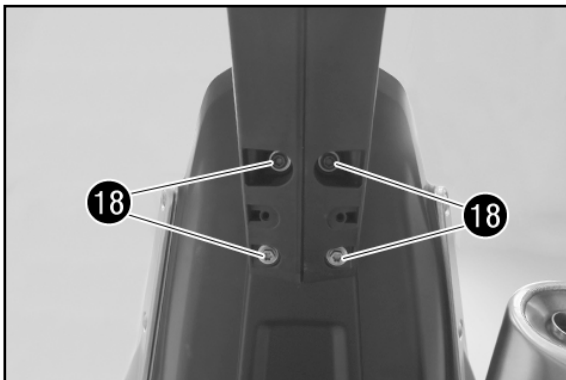

Blinker hinten 790 Duke

Montage

- Schrauben 18 entfernen.
- Kennzeichenträger auf dem Hinterrad ablegen.

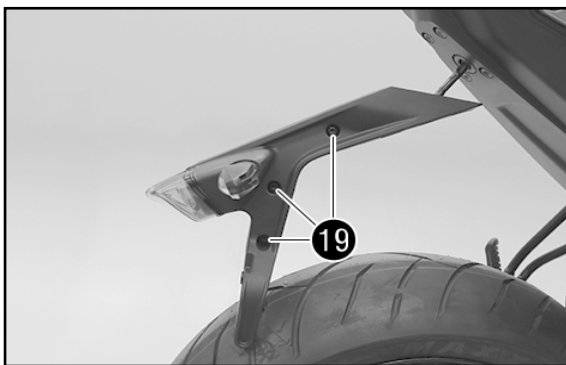

- Schrauben 19 entfernen.
- Kennzeichenträgerhälften nach außen schwenken und im Bereich B aushängen.
- Rücklicht auf dem Hinterrad ablegen.

HINWEIS

Nach Bedarf kann der komplette Kennzeichenträger entfernt werden. Dafür unter der Soziussitzbank den entsprechenden Stecker abstecken und das Kabel mit Gummitülle ausfädeln.

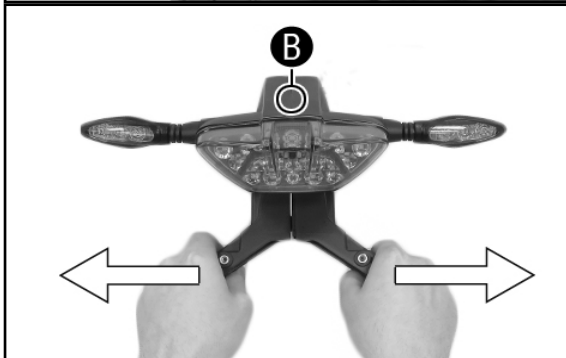

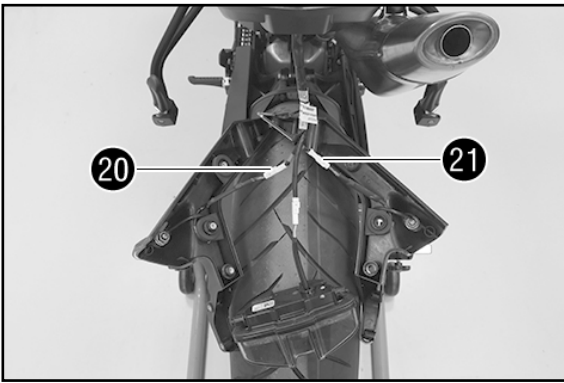

- Blinker-Steckerverbindung 20 und 21 trennen.
- Kennzeichenträgerhälften abnehmen.

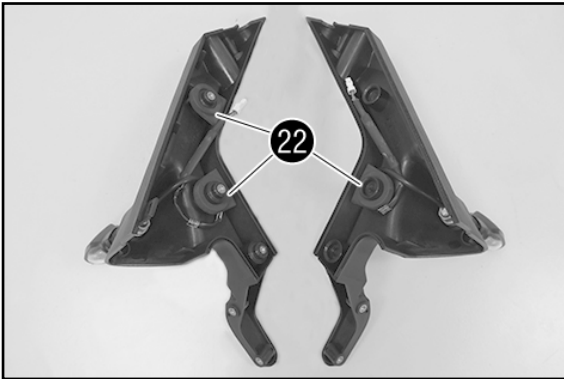

- Kabelhalter 22 entfernen.

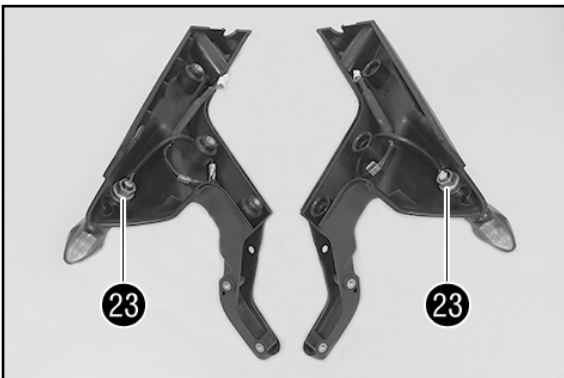

- Muttern 23 mit Scheiben entfernen.
- Blinker entfernen.

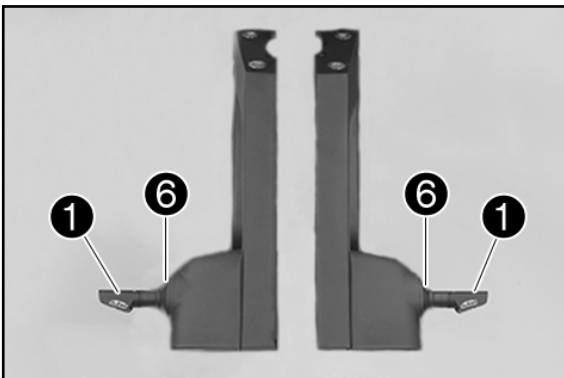

- Blinkeradapter 6 (Lieferumfang) am Blinker 1 (Lieferumfang) vormontieren.
- Blinker 1 (Lieferumfang) einfädeln und mit Blinkeradapter 6 positionieren.

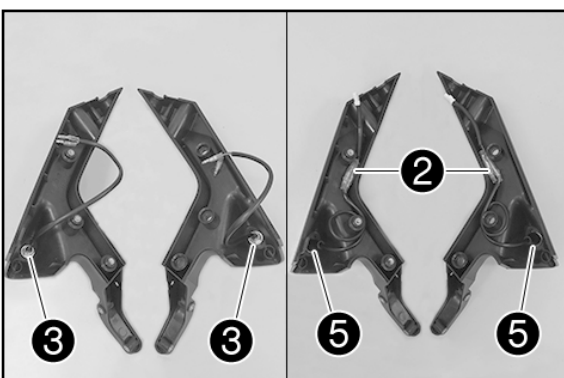

- Muttern 3 mit Scheiben 4 (alles Lieferumfang) montieren und festziehen.
- Schutzkappen 5 (Lieferumfang) montieren.
- Widerstände 2 (Lieferumfang) entsprechend der Farben anstecken.
- Kabel positionieren.

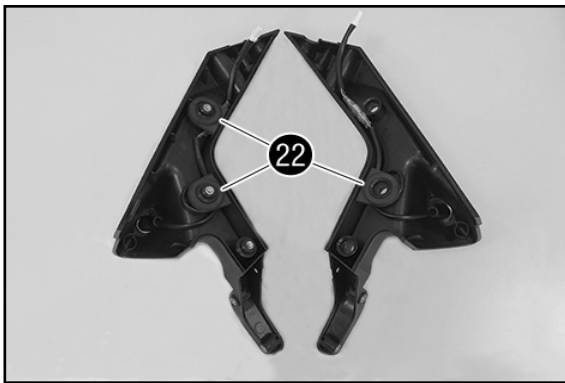

- Kabelhalter 22 mit der Lippe C nach innen montieren.

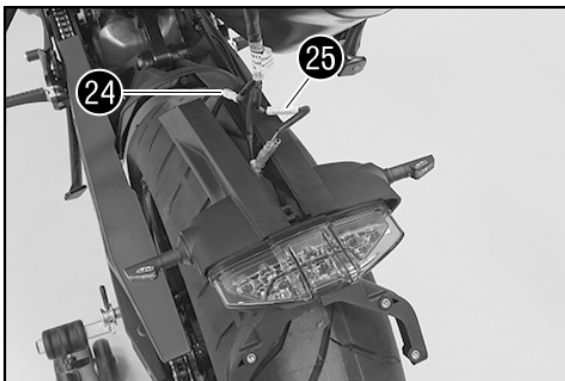
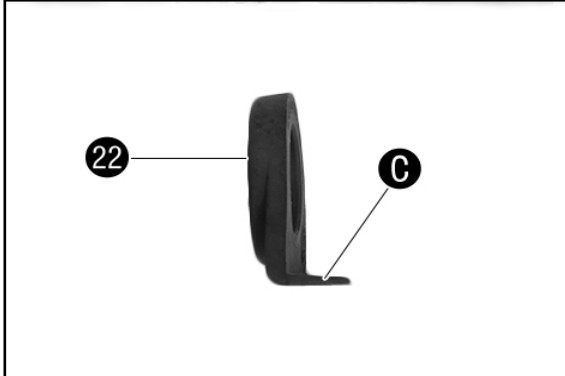

- Blinker-Steckerverbindung 24 und 25 zusammenstecken.
- Kennzeichenträgerhälften am Rücklicht positionieren.
- Kabel spannungsfrei verlegen.

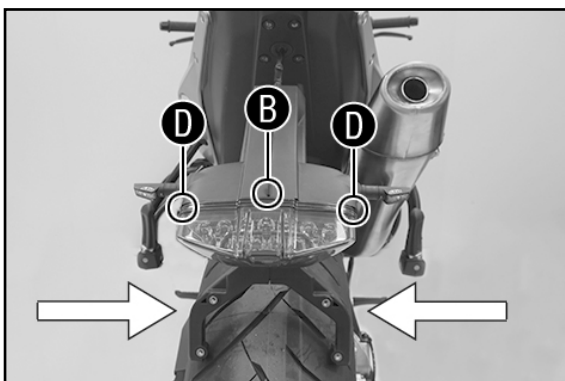

- Die Kennzeichenträgerhälften im Bereich B einrasten und das Rücklicht in den Bereichen D einhängen.
- Kennzeichenträgerhälften zusammenstecken.

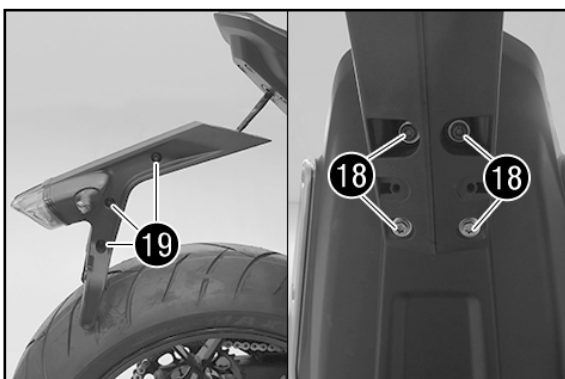

- Schrauben 19 montieren und mit 5 Nm festziehen.
- Kennzeichenträger positionieren.
- Schrauben 18 montieren und mit 10 Nm (Loctite 243) festziehen.

Nacharbeit

- Funktion der Beleuchtung kontrollieren.



Blinker vorn 1290 Duke R

Montage

- Zündung ausschalten.
- Einstellschraube 7 komplett herausdrehen.

HINWEIS

Die Einstellschraube ist durch eine Kugelkopfhalterung an der Scheinwerfermaske befestigt.
Die Einstellschraube nicht aus der Kugelkopfhalterung ziehen.

- Scheinwerfermaske leicht nach vorn schwenken und ggf. Stecker 8 abstecken.

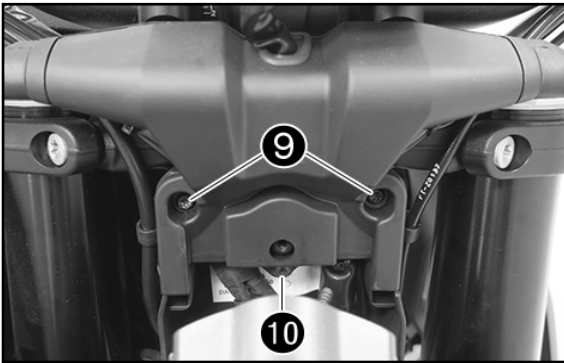

- Schrauben 9 entfernen.
- Schraube 10 entfernen.

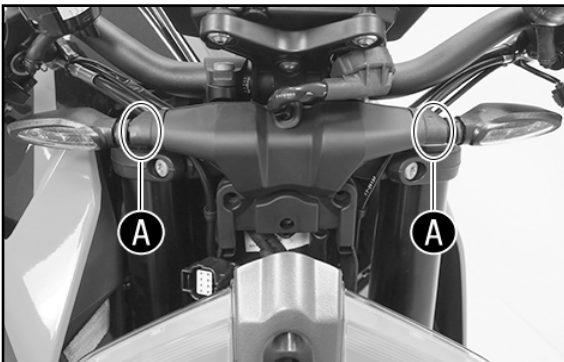

- Blinker im Bereich A greifen und vorsichtig entgegen der Fahrtrichtung drücken.

✓ Die Abdeckung löst sich.

- Abdeckung nach oben entfernen.

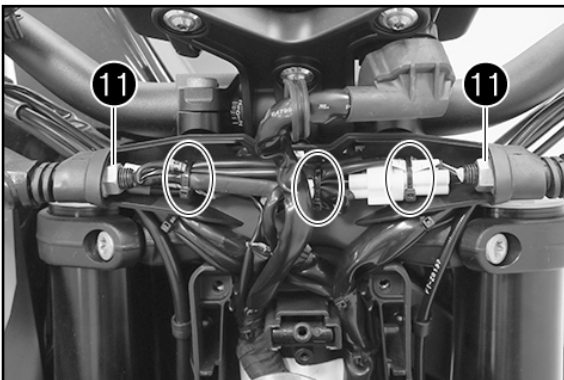

- Muttern 11 komplett vom Gewinde lösen.
- Kabelbinder entfernen.

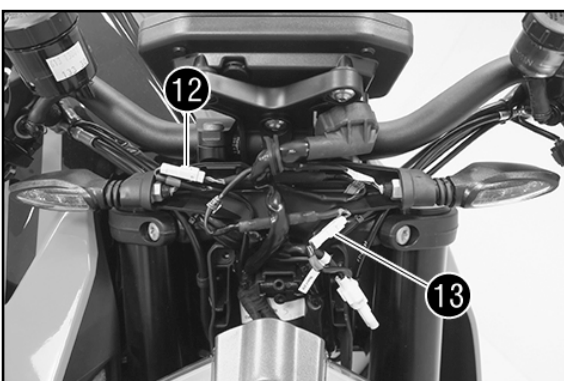

- Blinker-Stecker rechts 12 und links 13 abstecken.
- Blinker ausfädeln und mit Muttern und Scheiben entfernen.

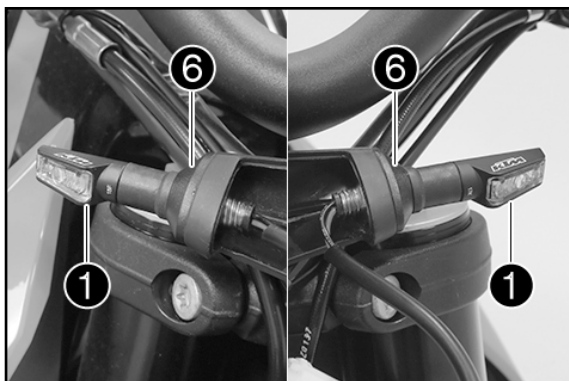

- Blinkeradapter ⑥ (Lieferumfang) am Blinker ① (Lieferumfang) vormontieren.
- Blinker ① (Lieferumfang) einfädeln und mit Blinkeradapter ⑥ positionieren.

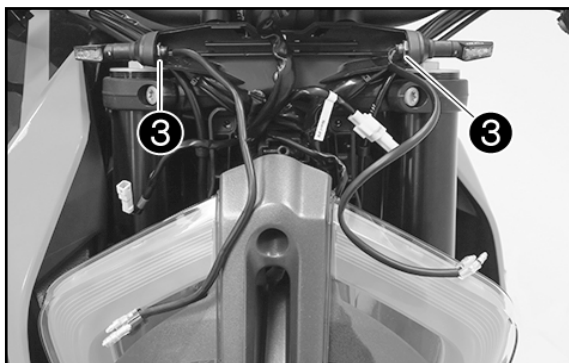

- Muttern ③ mit Scheiben ④ (alles Lieferumfang) montieren und festziehen.

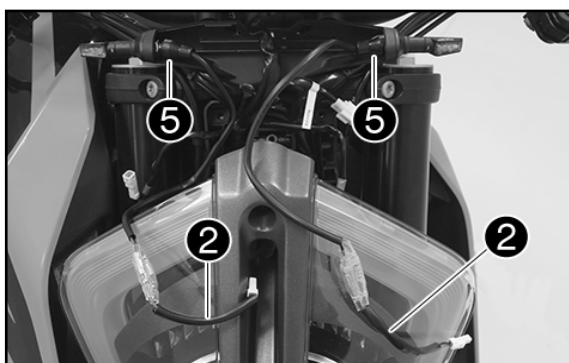

- Schutzkappen ⑤ (Lieferumfang) montieren.
- Widerstände ② (Lieferumfang) entsprechend der Farben anstecken.

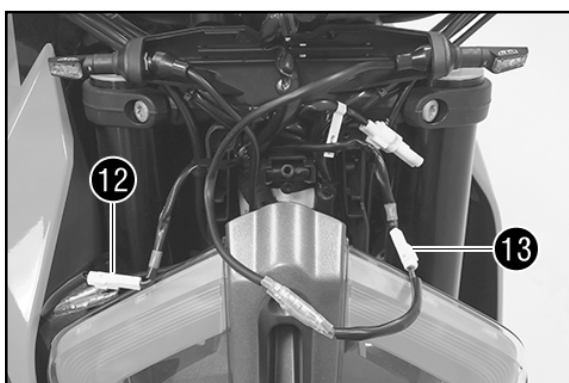

- Blinker-Stecker rechts ⑫ und links ⑬ anstecken.

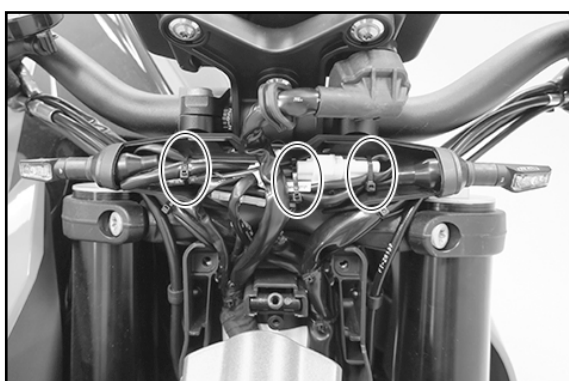

- Alle Kabel spannungsfrei verlegen und mit Kabelbinder sichern.

! VORSICHT

Sicher stellen, dass das Kabel nicht geknickt oder geklemmt werden kann!

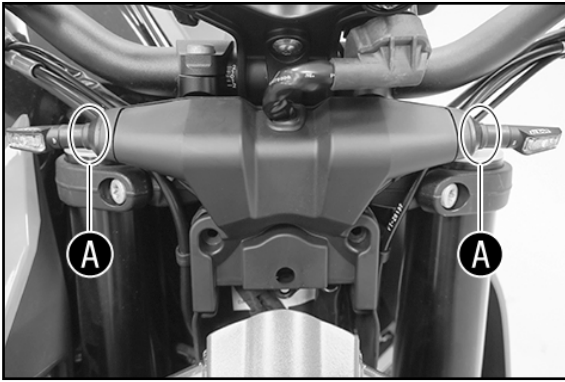

- Abdeckung und Kabel mit Gummitülle positionieren.
 - Blinker im Bereich **A** greifen und vorsichtig entgegen der Fahrtrichtung drücken, gleichzeitig die Abdeckung festdrücken.
- ✓ Die Abdeckung rastet mit einem hörbaren Klicken ein.

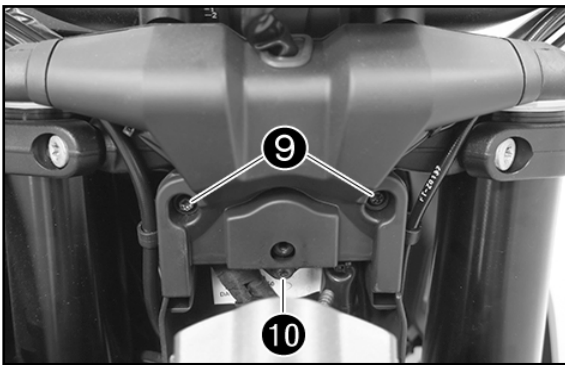

- Schrauben **9** montieren und mit 5 Nm festziehen.
- Schraube **10** montieren und mit 5 Nm festziehen.

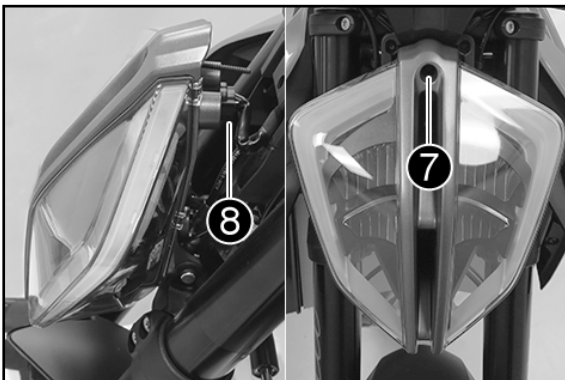

- Ggf. Stecker **8** anstecken.
- Scheinwerfermaske positionieren.
- Einstellschraube **7** montieren.

Nacharbeit

- Scheinwerfereinstellung kontrollieren (s. Bedienungsanleitung).
- Leuchtweite des Scheinwerfers einstellen (s. Bedienungsanleitung).
- Funktion der Beleuchtung kontrollieren.

Blinker hinten 1290 Super Duke R

Vorarbeit

- Soziussitzbank abnehmen (s. Bedienungsanleitung).

Montage

- Stecker **14** abstecken.
- Schrauben **15** entfernen.
- Kennzeichenträger entfernen.

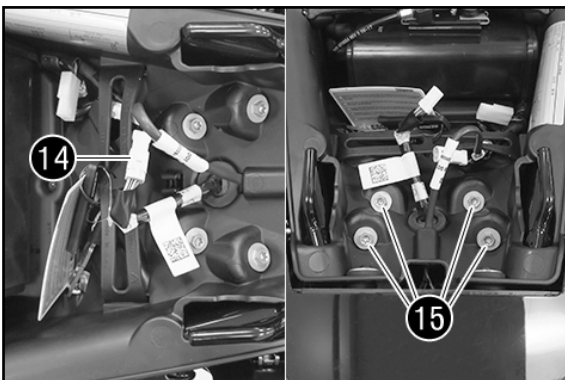

- Schrauben **16** entfernen.
- Schrauben **17** entfernen.

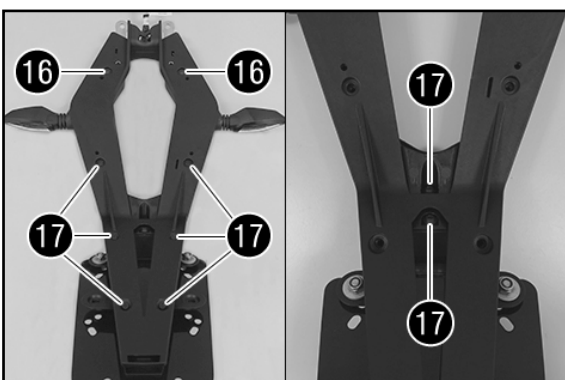

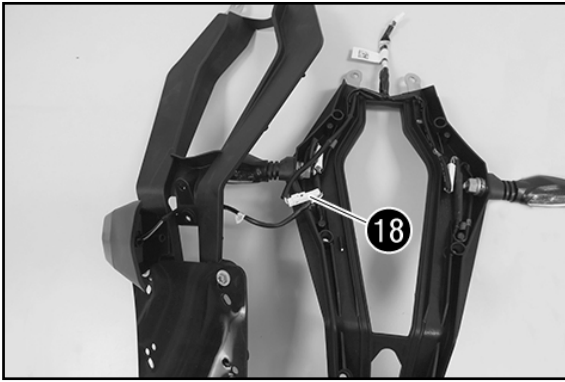

- Abdeckung abziehen.
- Kabel Kennzeichenbeleuchtung ausfädeln und Stecker 18 abstecken.
- Abdeckung mit Kennzeichenbeleuchtung abnehmen.

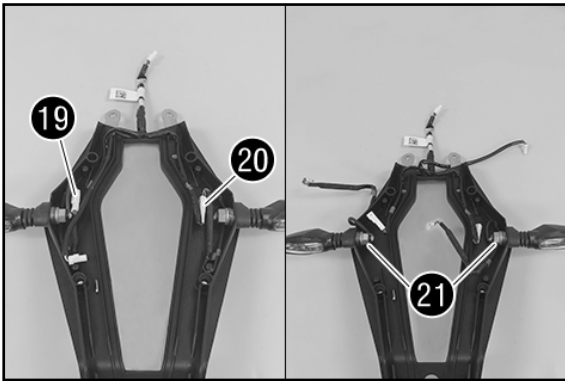

- Alle Kabel frei legen.
- Blinker-Stecker links 19 und rechts 20 abstecken.
- Muttern 21 komplett vom Gewinde lösen.
- Blinker ausfädeln und mit Muttern und Scheiben entfernen.

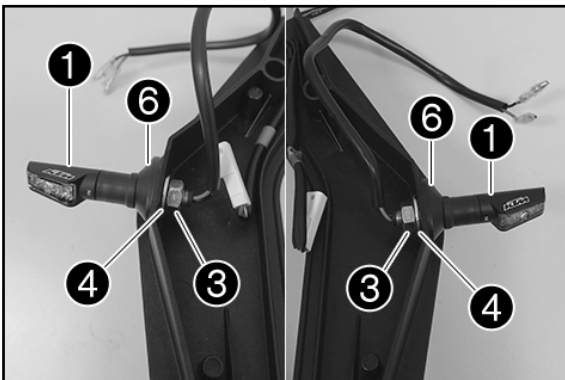

- Blinkeradapter 6 am Blinker 1 (alles Lieferumfang) vormontieren.
- Montagelöcher für Blinkeradapter 6 mit geeignetem Werkzeug aufbohren.
- Blinker 1 einfädeln und mit Blinkeradapter 6 positionieren.
- Muttern 3 mit Scheiben 4 (alles Lieferumfang) montieren und festziehen.

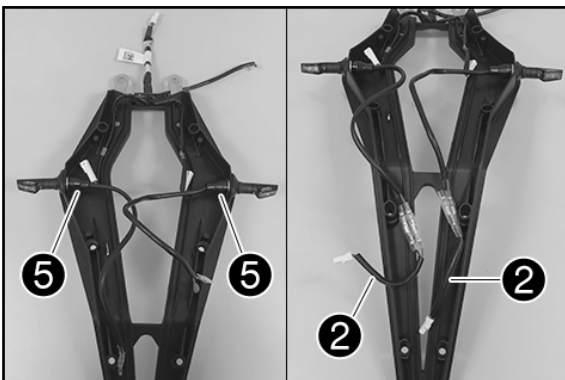

- Schutzkappen 5 (Lieferumfang) montieren.
- Widerstände 2 (Lieferumfang) entsprechend der Farben anstecken.

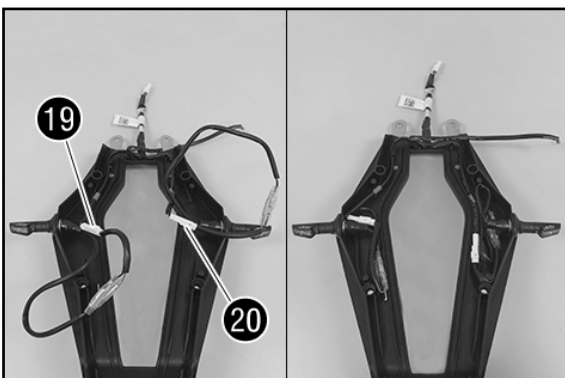

- Blinker-Stecker links 19 und rechts 20 anstecken.
- Alle Kabel spannungsfrei verlegen.

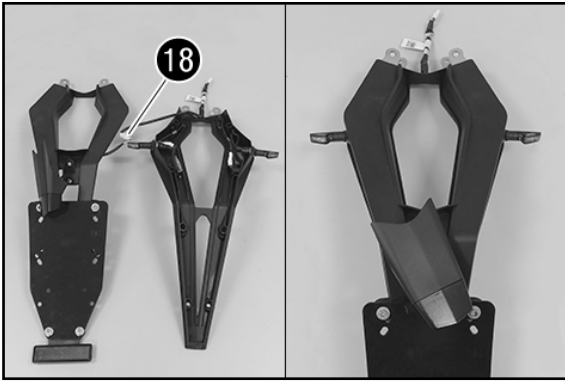

- Stecker Kennzeichenbeleuchtung 18 anstecken.
- Abdeckung positionieren.
- Kabel Kennzeichenbeleuchtung spannungsfrei verlegen.

! VORSICHT

Sicher stellen, dass die Kabel nicht geknickt oder geklemmt werden können!

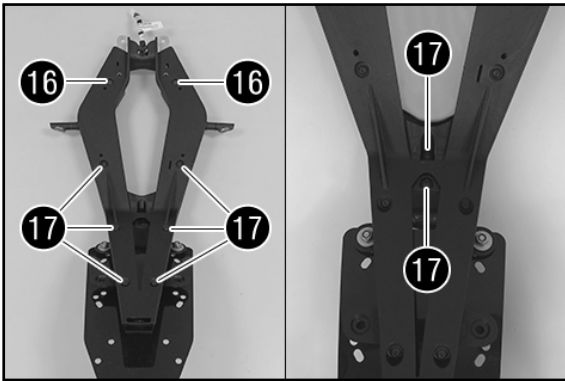

- Schrauben 16 montieren, aber noch nicht festziehen.
- Schrauben 17 montieren, aber noch nicht festziehen.
- Kennzeichenbeleuchtung positionieren und Schrauben 17 montieren und festziehen.
- Alle Schrauben 16 und 17 festziehen.

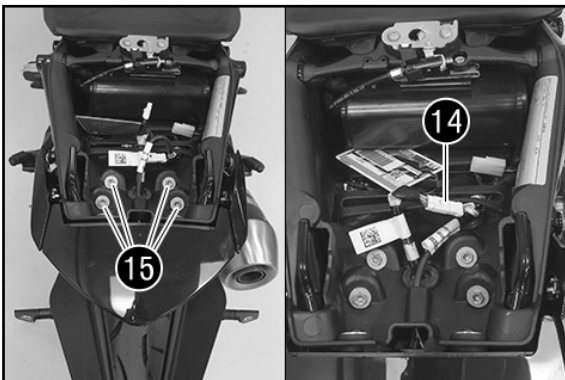

- Kennzeichenträger positionieren und Kabel oben durchfädeln.
- Schrauben 15 montieren und mit 10 Nm (Loctite 243) festziehen.
- Stecker 14 anstecken.

Nacharbeit

- Soziussitzbank montieren (s. Bedienungsanleitung).
- Funktion der Beleuchtung kontrollieren.

Blinker hinten 1290 Super Duke GT

Vorarbeit

- Soziussitzbank abnehmen (s. Bedienungsanleitung).

Montage

- Stecker 7 abstecken.



- Schrauben 8 entfernen.
- Kennzeichenträger entfernen.



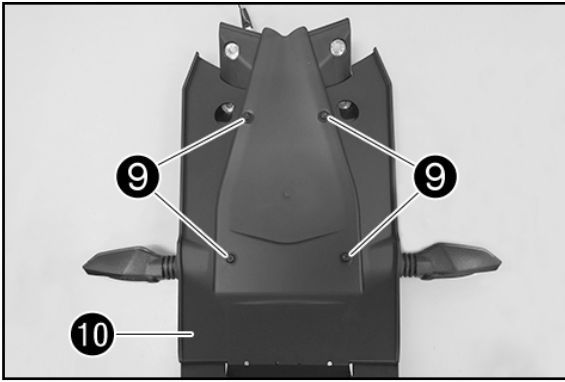

- Schrauben 9 entfernen.
- Abdeckung 10 entfernen.

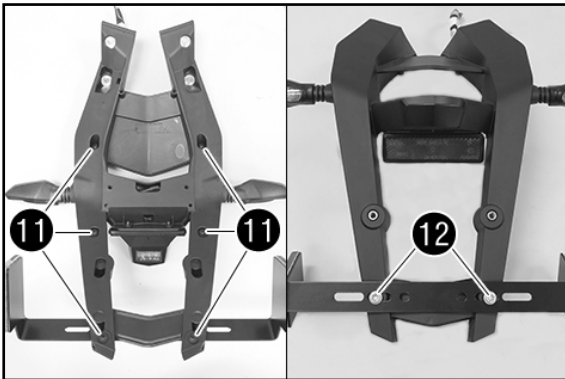

- Schrauben 11 entfernen.

US Modelle:

- Schrauben 12 entfernen.
- Reflektoren abnehmen.

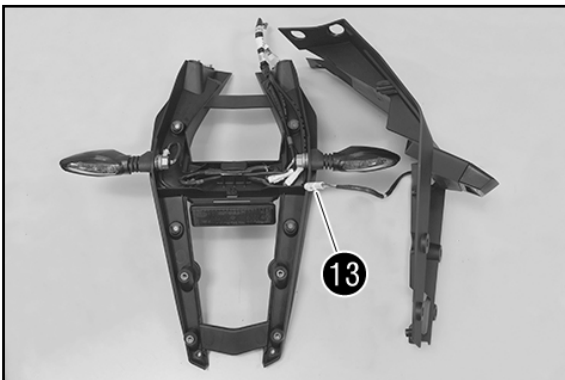

- Abdeckung abziehen.

- Kabel Kennzeichenbeleuchtung ausfädeln und Stecker 13 abstecken.
- Abdeckung mit Kennzeichenbeleuchtung abnehmen.

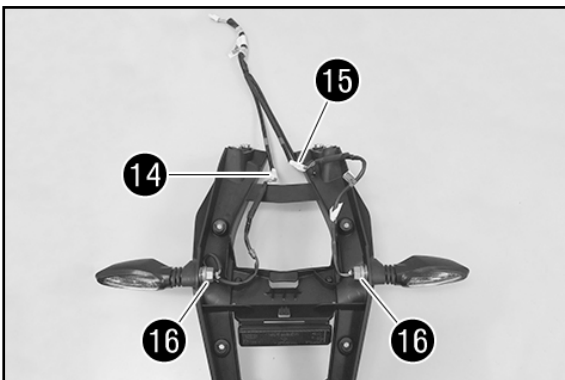

- Alle Kabel frei legen.
- Blinker-Stecker links 14 und rechts 15 abstecken.

- Muttern 16 komplett vom Gewinde lösen.
- Blinker ausfädeln und mit Muttern und Scheiben entfernen.

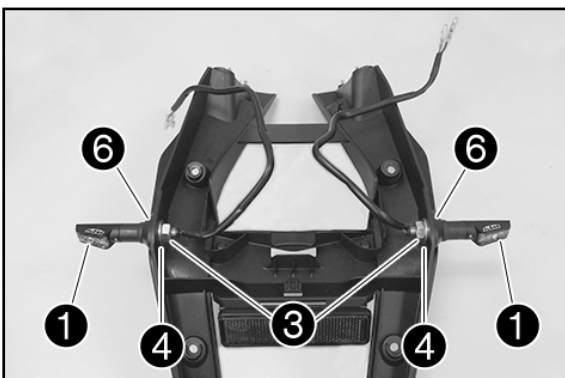

- Blinkeradapter 6 am Blinker 1 (alles Lieferumfang) vormontieren.

- Blinker 1 einfädeln und mit Blinkeradapter 6 positionieren.
- Muttern 3 mit Scheiben 4 (alles Lieferumfang) montieren und festziehen.

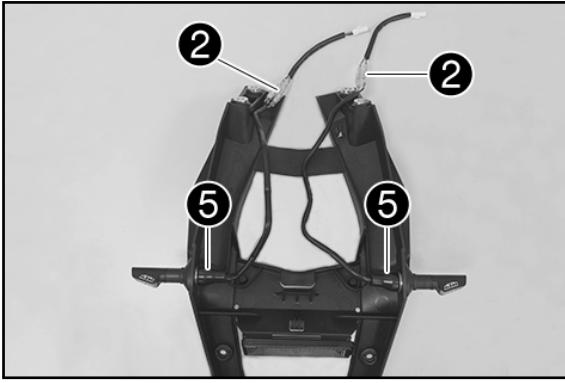

- Schutzkappen ⑤ (Lieferumfang) montieren.
- Widerstände ② (Lieferumfang) entsprechend der Farben anstecken.

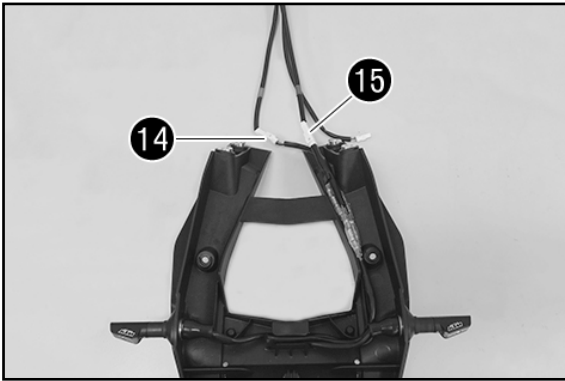

- Alle Kabel spannungsfrei verlegen.
- Blinker-Stecker links ⑭ und rechts ⑮ anstecken.

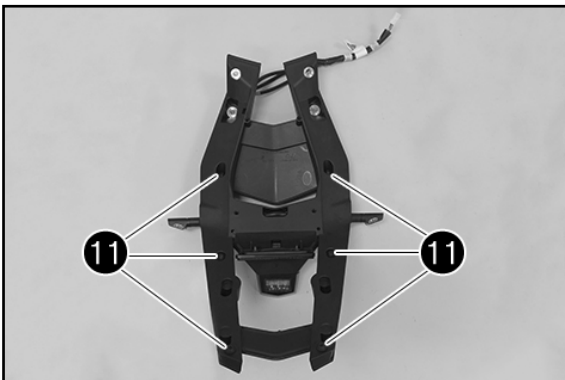

- Stecker Kennzeichenbeleuchtung ⑬ anstecken.
- Kabel Kennzeichenbeleuchtung spannungsfrei verlegen.
- Abdeckung positionieren.

! VORSICHT

Sicher stellen, dass die Kabel nicht geknickt oder geklemmt werden können!

- Schrauben ⑪ montieren und festziehen.

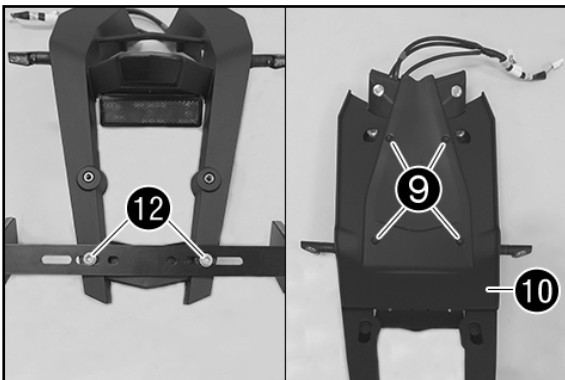

US Modelle:

- Reflektoren positionieren.
- Schrauben ⑫ montieren und festziehen.

- Abdeckung ⑩ positionieren.
- Schrauben ⑨ montieren und festziehen.

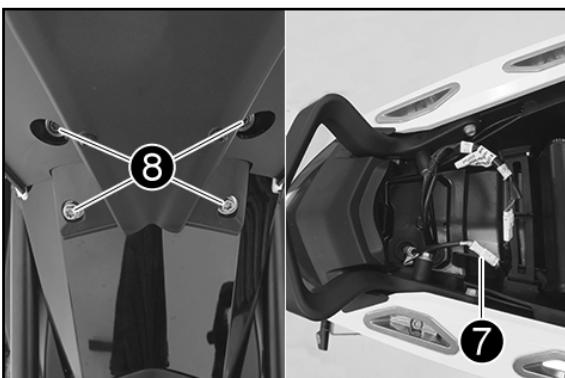

- Kennzeichenträger positionieren und Kabel oben durchfädeln.
- Schrauben ⑧ montieren und mit 10 Nm (Loctite 243) festziehen.
- Stecker ⑦ anstecken.

Nacharbeit

- Soziussitzbank montieren (s. Bedienungsanleitung).
- Funktion der Beleuchtung kontrollieren.

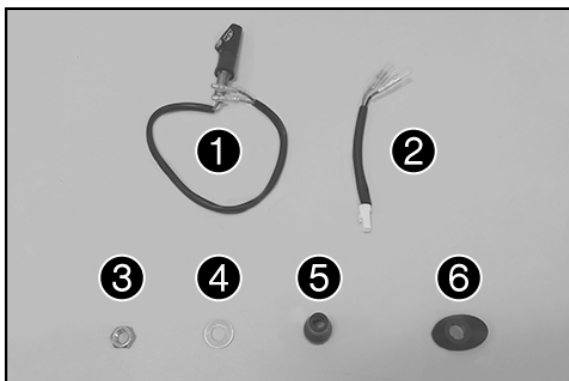

Scope of supply

- 1x turn signal ①
- 1x resistance ②
- 1x nut ③
- 1x washer ④
- 1x protection cap ⑤
- 1x turn signal adapter ⑥

Front turn signal 790 Duke

Assembly

- Switch off the ignition system.
- Remove screws ⑦.

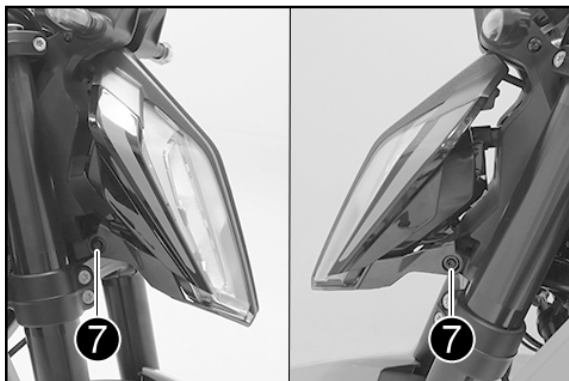

- Completely unscrew adjusting screw ⑧.

NOTE

The adjusting screw is fastened to the headlight mask by a ball head holder.
Do not pull the adjusting screw out of the ball head adjuster.

- Swivel the headlight mask slightly forwards and disconnect socket connector ⑨.
- Take off the headlight.

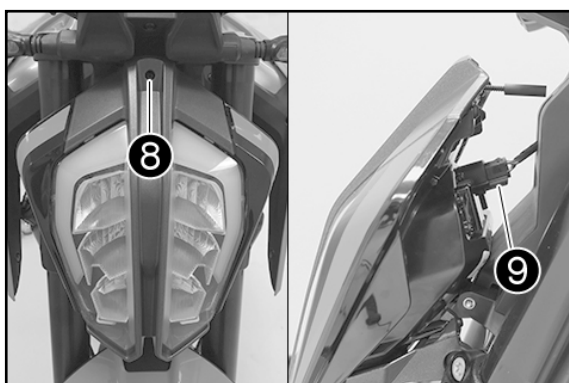

- Remove screws ⑩.
- Remove screws ⑪.
- Remove screws ⑫.

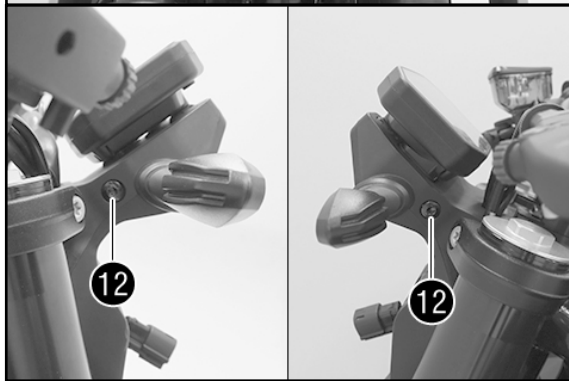
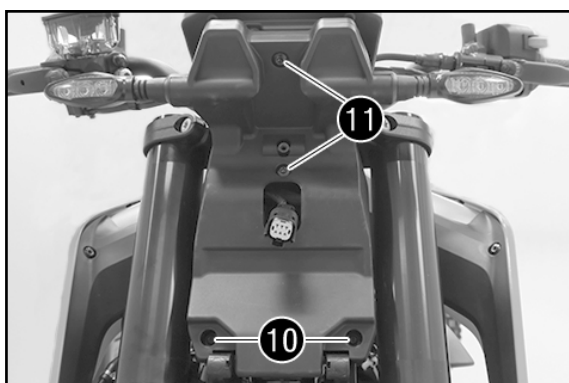

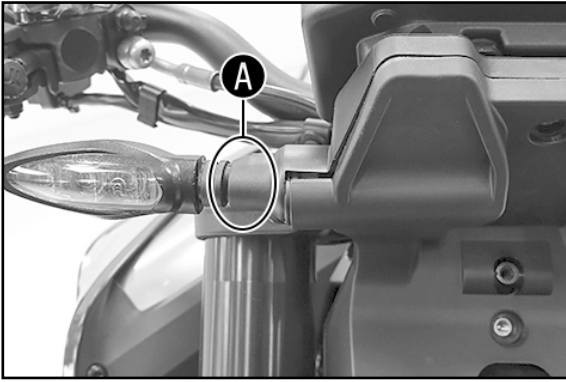

- Hold turn signal in area **A** and carefully press against the direction of travel.

✓ The cover is detached as illustrated.

- Repeat the operation on the opposite side.
- Remove the cover.

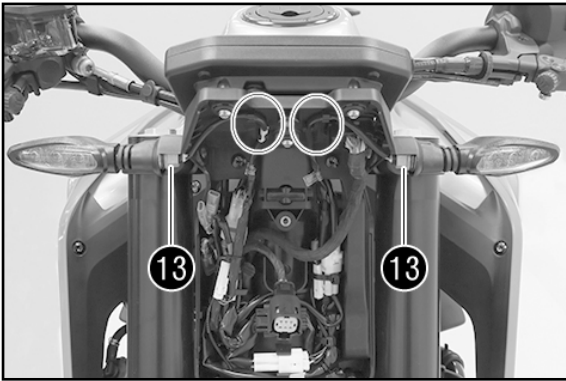

- Loosen nuts **13** fully from thread.
- Remove turn signal cable from the attachment at the top.

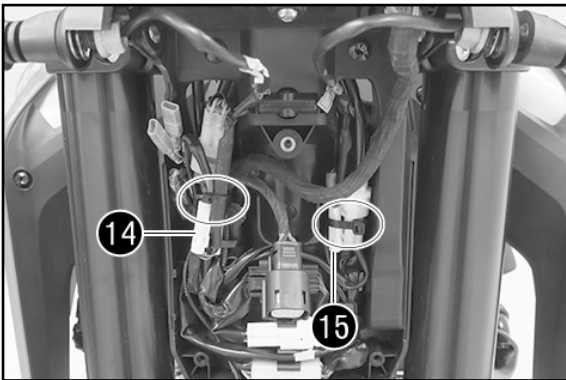

- Remove the cable tie.
- Disconnect turn signal plug-in connectors on the right **14** and left **15**.
- Remove turn signal with nuts and washers.

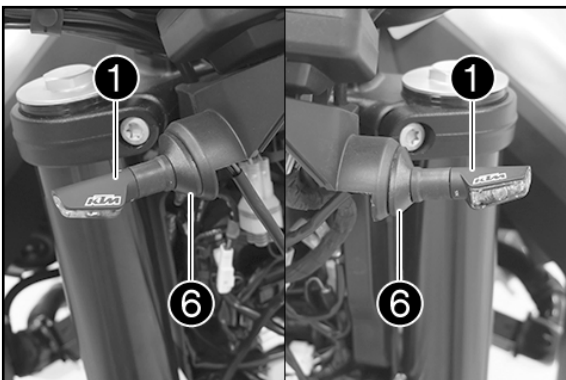

- Preassemble turn signal adapter **6** (included) on the turn signal **1** (included).
- Thread in turn signal **1** (included) and position turn signal adapter **6**.

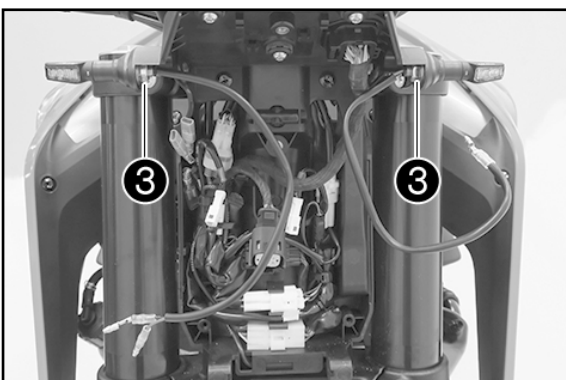

- Mount nuts **3** with washers **4** (all included) and tighten.

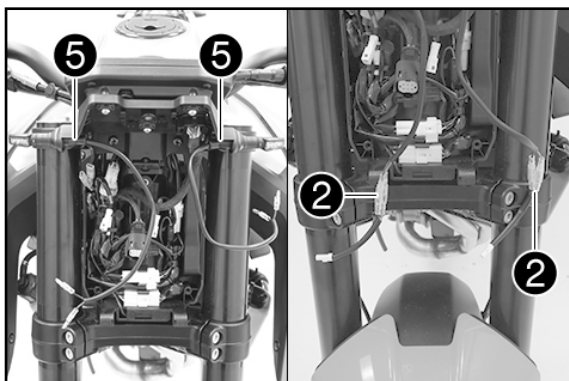

- Mount protection caps 5 (included).
- Plug in resistances 2 (included) according to the colors.

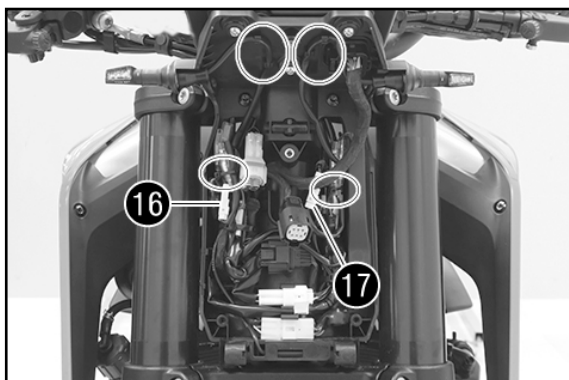

- Join turn signal plug-in connectors 16 and 17.
- Mount turn signal cable in the brackets at the top.
- Route all cables without tension and secure with a cable tie.

! ATTENTION

Ensure that the cable can neither be kinked or pinched!

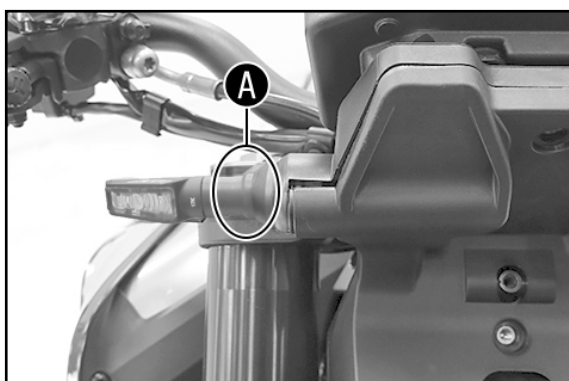

- Position cover, guiding the headlight plug-in connector through the opening in the process.
- Hold turn signal in the area A and carefully press against the direction of travel, while pressing the cover tight at the same time.

✓ The cover engages with an audible click.

- Repeat the operation on the opposite side.

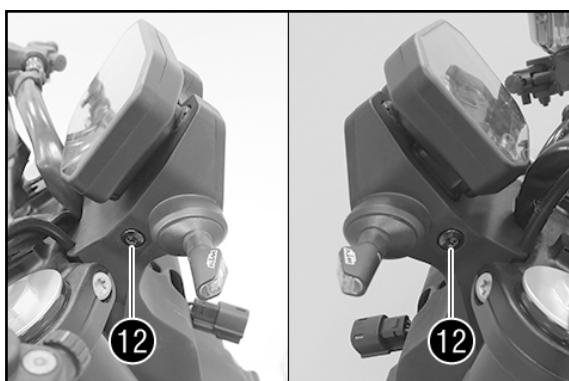

- Mount screws 12 and tighten to 5 Nm.
- Mount screws 11 and tighten to 5 Nm.
- Mount screws 10 and tighten to 2 Nm.

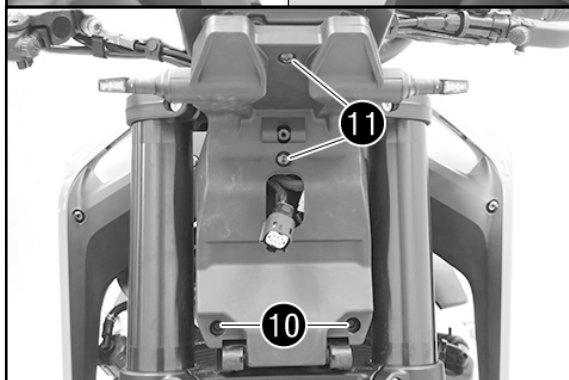

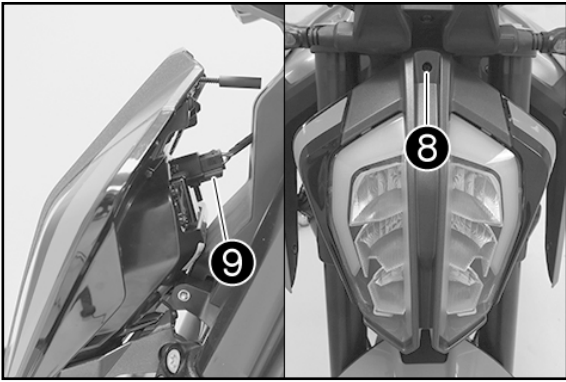

- Plug in connector 9.
- Position the headlight mask.
- Mount adjusting screw 8.

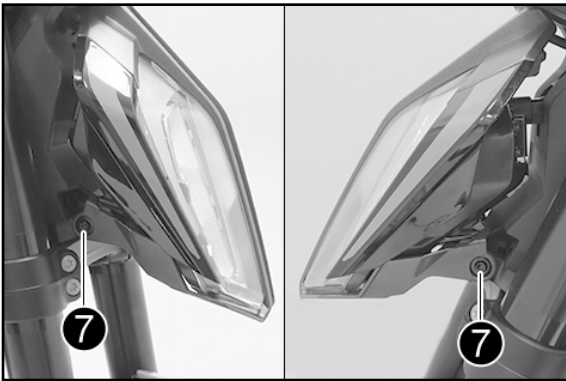

- Mount screws 7 and tighten to 2 Nm.

Final steps

- Check headlight setting (see Owner's Manual).
- Adjust headlight range of the headlight (see Owner's Manual).
- Check that the lighting is functioning properly.

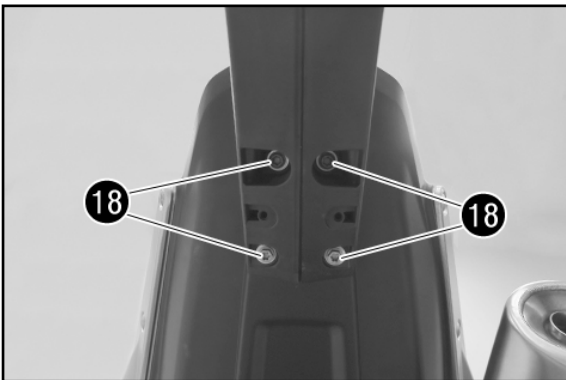

Rear turn signal 790 Duke

Assembly

- Remove screws 18.
- Place license plate holder support on the rear wheel.

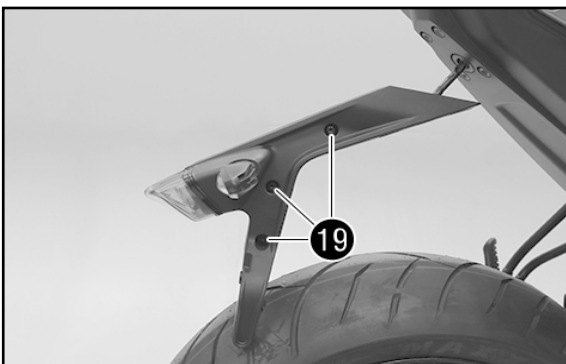

- Remove screws 19.
- Swivel each half of the license plate holder support outwards and detach in area B.
- Place tail light on the rear wheel.

NOTE

The complete license plate holder support can be removed if required. To do so, disconnect the relevant socket connectors under the passenger seat and slip out the cable with rubber grommet.

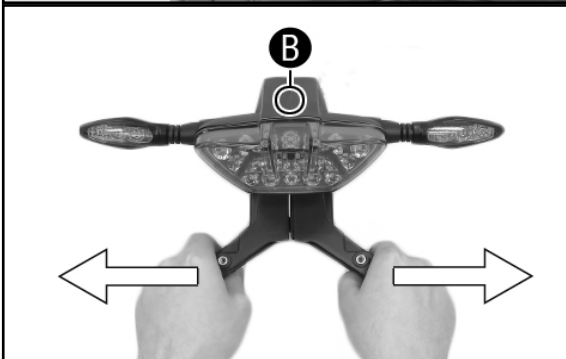

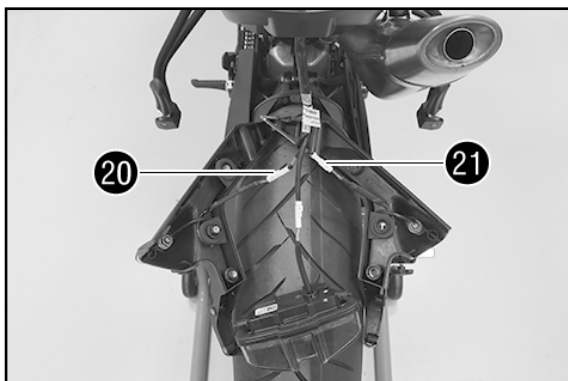

- Disconnect turn signal plug-in connector 20 and 21.
- Take off each half of the license plate holder support.

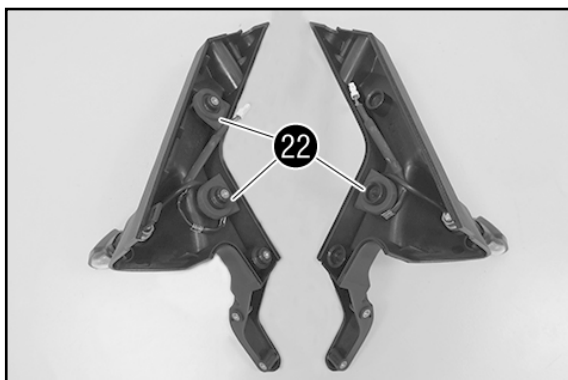

- Remove cable holder 22.

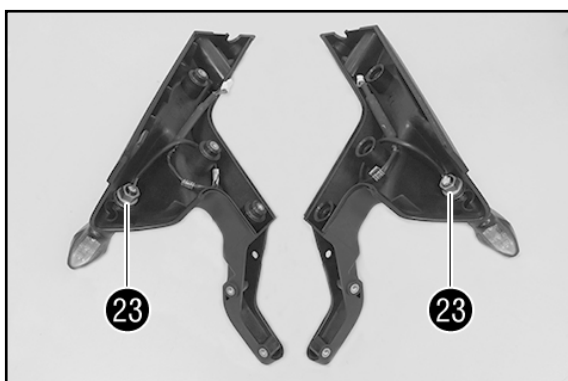

- Remove nuts 23 with the washers.
- Remove the turn signal.

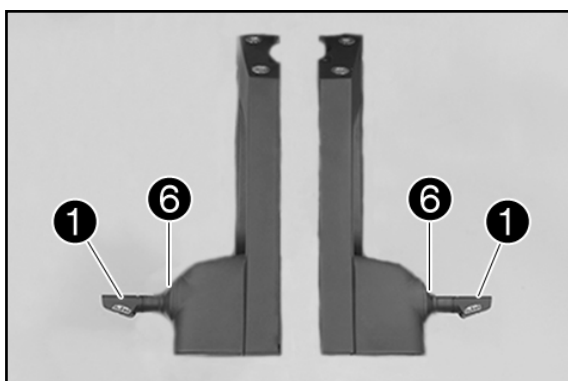

- Preassemble turn signal adapter 6 (included) on turn signal 1 (included).
- Thread in turn signal 1 (included) and position turn signal adapter 6.

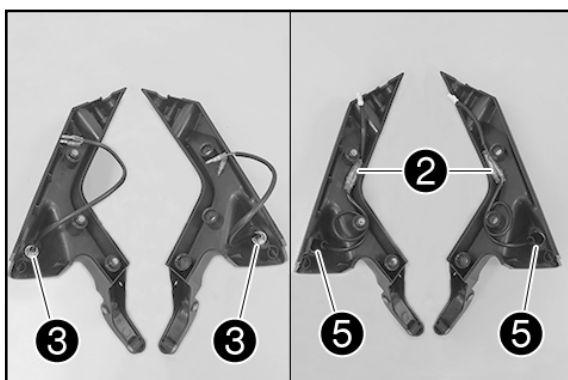

- Mount nuts 3 with washers 4 (all included) and tighten.
- Mount protection caps 5 (included).
- Plug in resistances 2 (included) according to the colors.
- Position the cables.

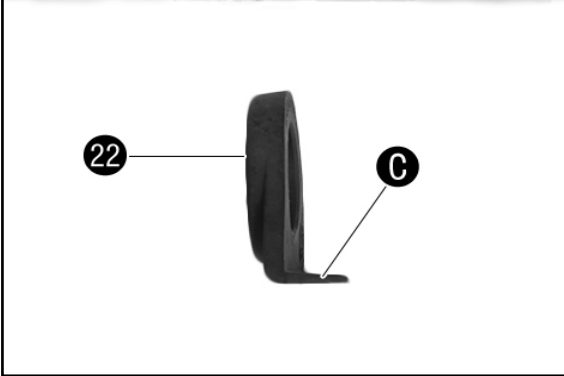
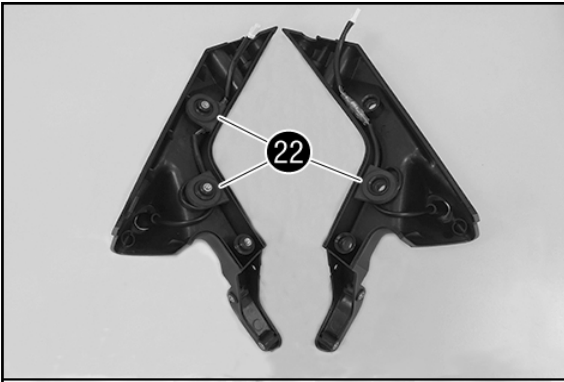

- Mount cable holder 22 with the lip C facing inward.

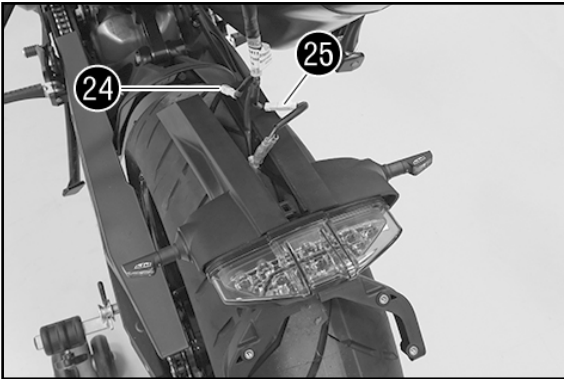

- Disconnect turn signal plug-in connectors 24 and 25.
 - Position each half of the license plate holder support on the tail light.
 - Route the cable without tension.

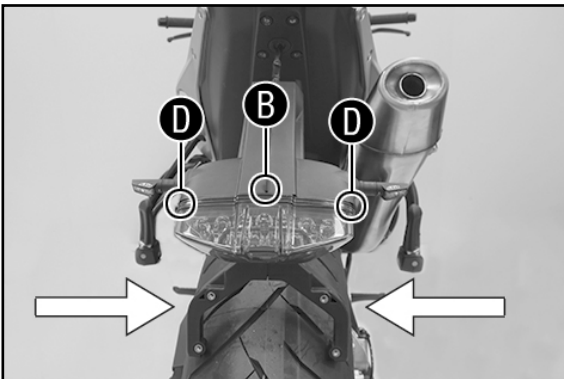

- Latch each half of license plate holder support into place in area B and hook in the tail light in areas D.
 - Join each half of license plate holder support.

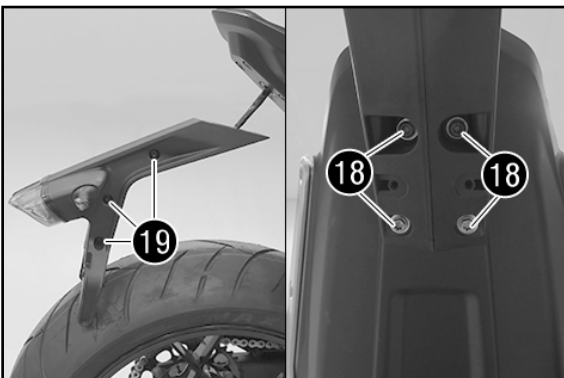

- Mount screws 19 and tighten to 5 Nm.
 - Position the license plate holder support.
 - Mount screws 18 and tighten to 10 Nm (Loctite 243).

Final steps

- Check that the lighting is functioning properly.

Front turn signal, 1290 Duke R

Assembly

- Switch off the ignition.
- Completely unscrew adjusting screw 7.

NOTE

The adjusting screw is fastened to the headlight mask by a ball head holder.

Do not pull the adjusting screw out of the ball head adjuster.

- Swivel the headlight mask slightly forward and disconnect socket connector 8 if applicable.

- Remove screws 9.
- Remove screw 10.

- Hold turn signal in area A and carefully press against the direction of travel.

✓ The cover is loosened.

- Remove cover upward.

- Loosen nuts 11 fully from thread.
- Remove the cable ties.

- Disconnect turn signal socket connector right 12 and left 13.
- Slip out the turn signals and remove with the nuts and washers.

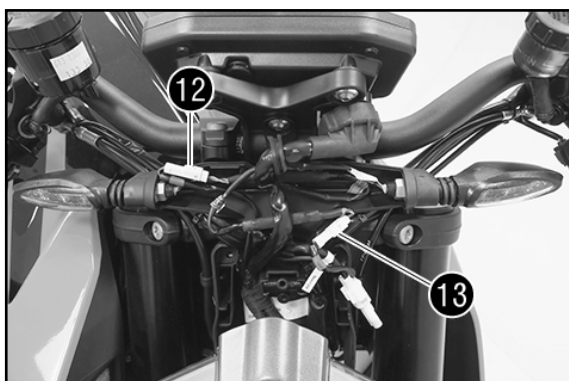
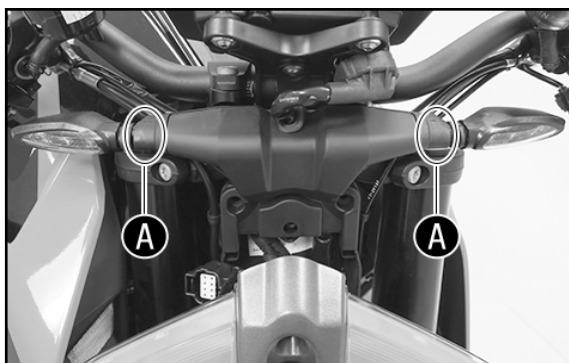
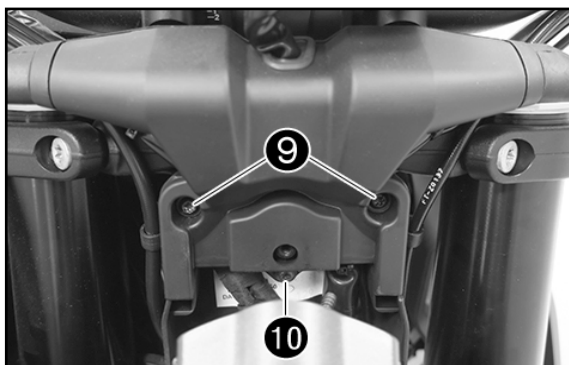
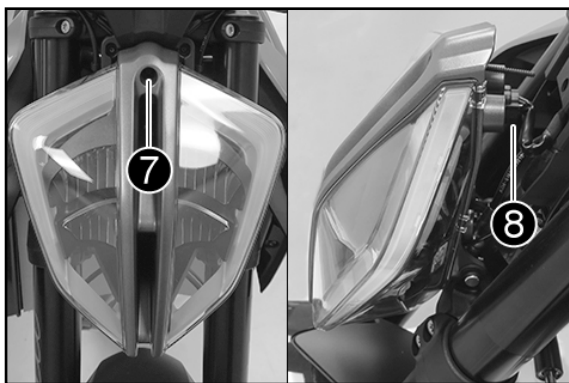

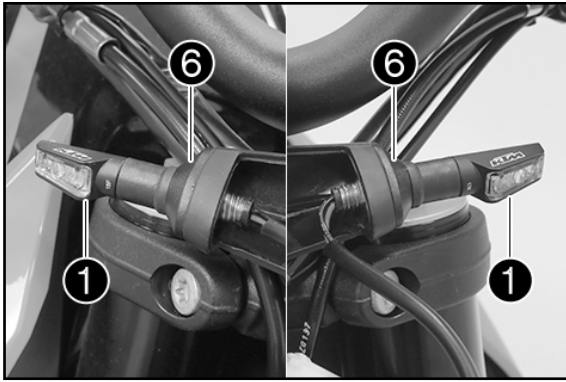

- Preassemble turn signal adapter ⑥ (included) on turn signal ① (included).
- Thread in turn signal ① (included) and position turn signal adapter ⑥.

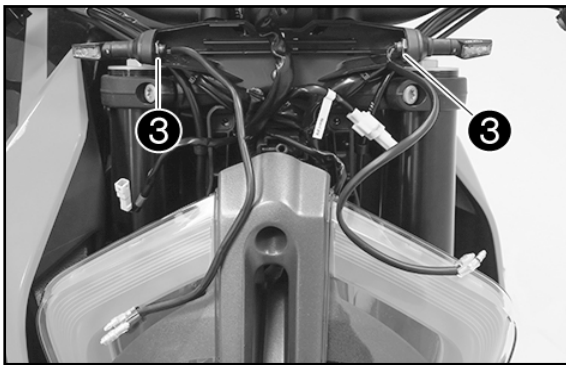

- Mount nuts ③ with washers ④ (all included) and tighten.

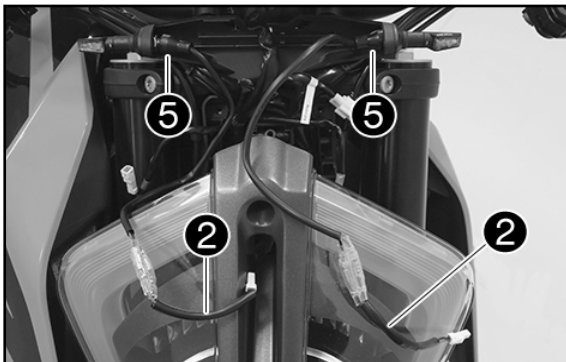

- Mount protection caps ⑤ (included).
- Plug in resistances ② (included) according to the colors.

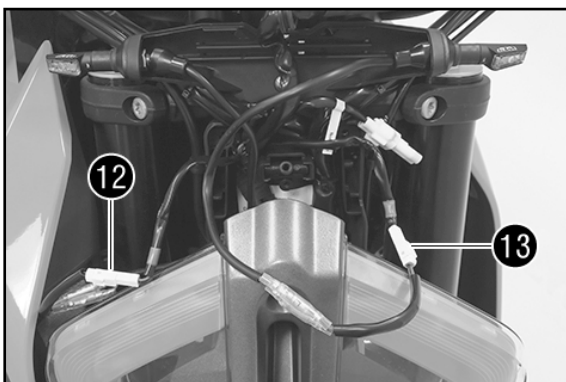

- Connect turn signal socket connector right ⑫ and left ⑬.

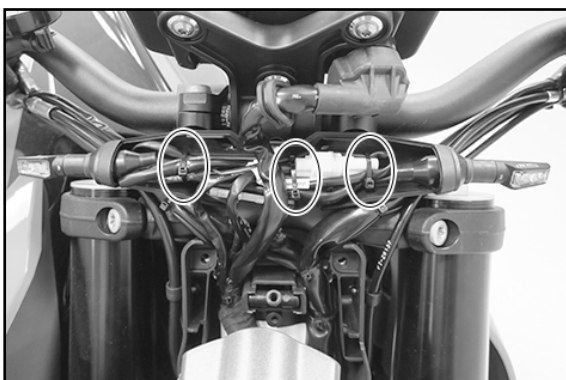

- Route all cables without tension and secure with a cable tie.

! ATTENTION
Ensure that the cable can neither be kinked or pinched!

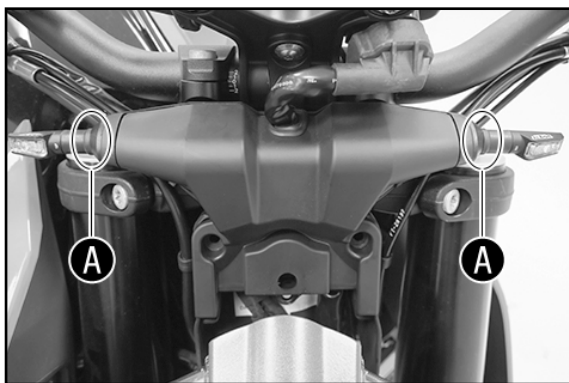

- Position cover and cable with rubber grommet.
 - Hold turn signal in area **A** and carefully press against the direction of travel while at the same time pressing the cover tight.
- ✓ The cover engages with an audible click.

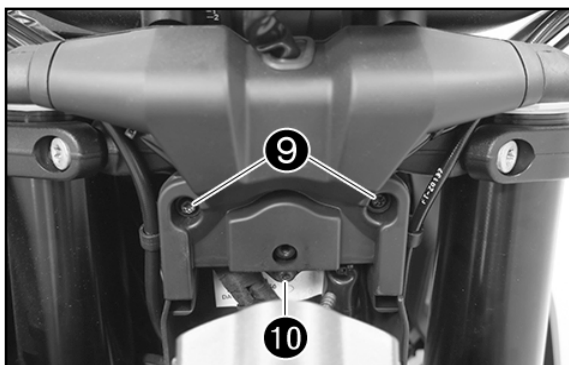

- Mount screws **9** and tighten to 5 Nm.
- Mount screw **10** and tighten to 5 Nm.

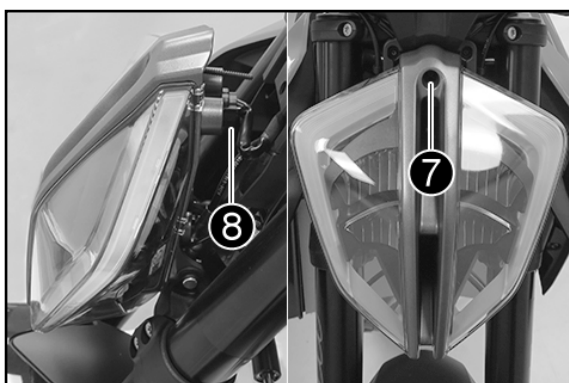

- If necessary, plug in socket connector **6**.
- Position the headlight mask.
- Mount adjusting screw **7**.

Final steps

- Check headlight setting (see Owner's Manual).
- Adjust headlight range of the headlight (see Owner's Manual).
- Check that the lighting is functioning properly.

Rear turn signal, 1290 Super Duke R

Preliminary work

- Take off passenger seat (see owner's manual).

Assembly

- Disconnect socket connector **14**.
- Remove screws **15**.
- Remove the license plate holder support.

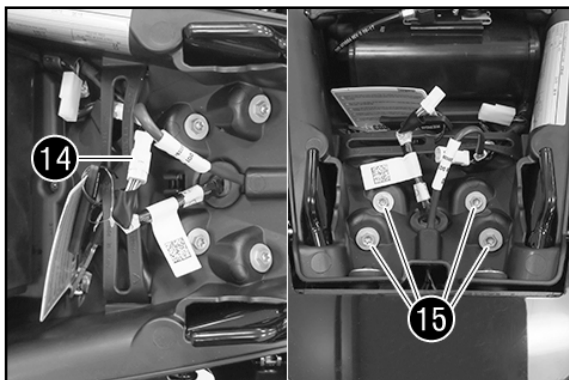

- Remove screws **16**.
- Remove screws **17**.

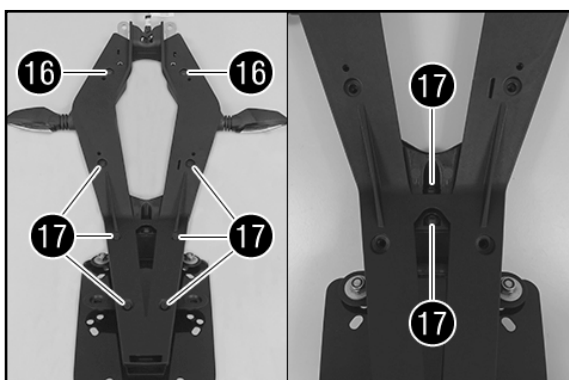

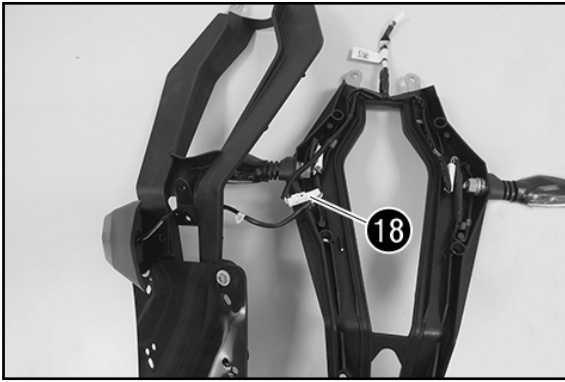

- Pull off cover.
- Slip out the cable for the license plate lighting and disconnect socket connector 18.
- Remove the cover with the license plate lighting.

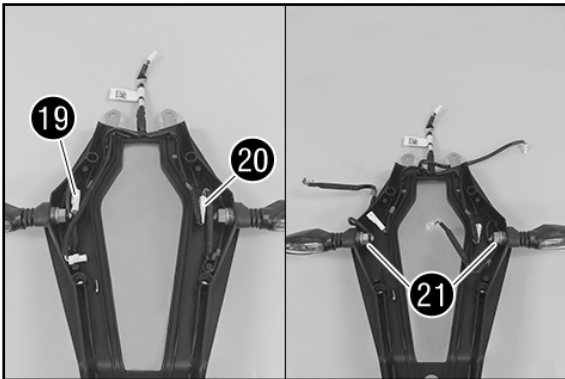

- Expose all cables.
- Disconnect turn signal socket connector left 19 and right 20.
- Loosen nuts 21 fully from thread.
- Slip out the turn signals and remove with the nuts and washers.

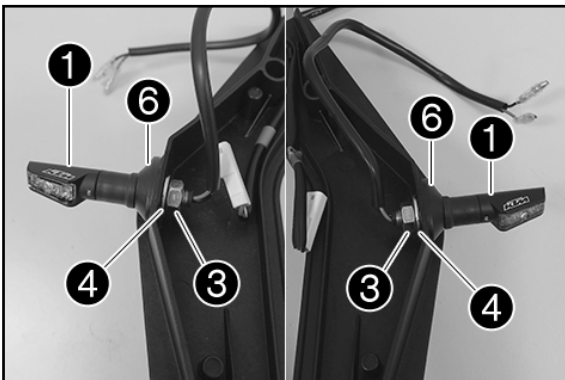

- Preassemble turn signal adapter 6 on turn signal 1 (all included).
- Drill out the mounting holes for turn signal adapter 6 with a suitable tool.
- Thread in turn signal 1 and position with turn signal adapter 6.
- Mount nuts 3 with washers 4 (all included) and tighten.

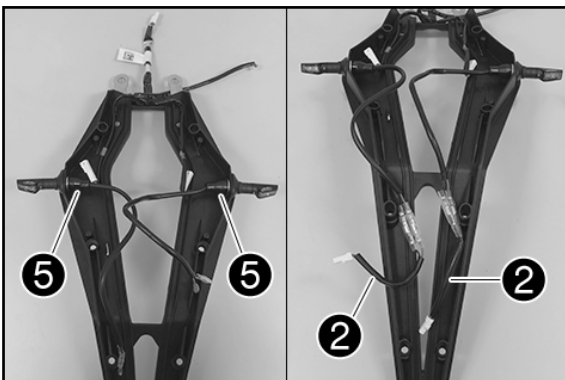

- Mount protection caps 5 (included).
- Plug in resistances 2 (included) according to the colors.

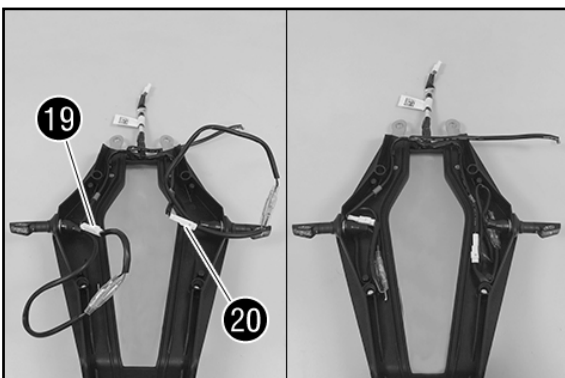

- Plug in turn signal socket connector left 19 and right 20.
- Route all cables without tension.

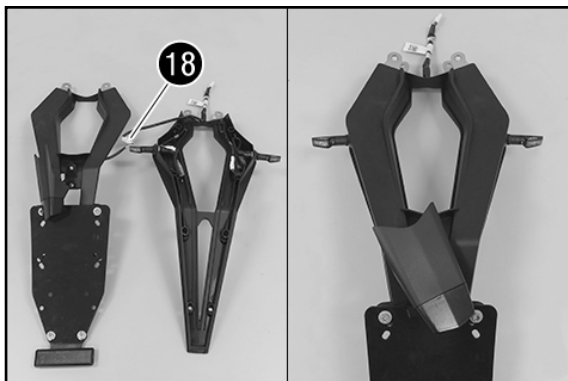

- Plug in license plate lighting 18.
- Position the cover.
- Lay the license plate lighting cable without tension.

! ATTENTION
Ensure that the cables can neither become kinked or pinched!

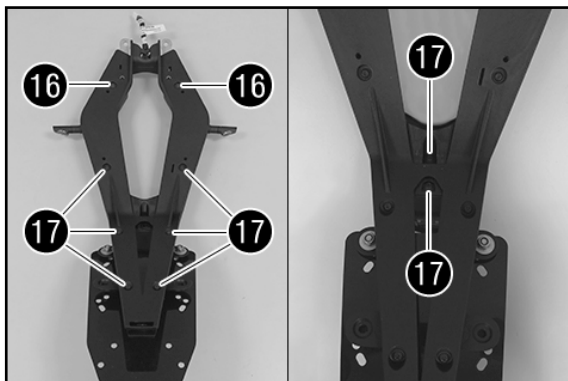

- Mount screws 16, but do not tighten them yet.
- Mount screws 17, but do not tighten them yet.
- Position the license plate lighting and mount and tighten screws 17.
- Tighten all screws 16 and 17.

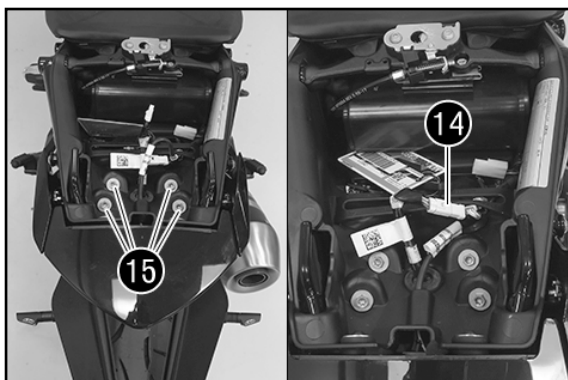

- Position the license plate holder support and thread the cable through the top.
- Mount screws 15 and tighten to 10 Nm (Loctite 243).
- Connect socket connector 14.

Final steps

- Mount the passenger seat (see owner's manual).
- Check that the lighting is functioning properly.

Rear turn signal, 1290 Super Duke GT

Preliminary work

- Take off passenger seat (see owner's manual).

Assembly

- Unplug socket connector 7.



- Remove screws 8.
- Remove the license plate holder support.

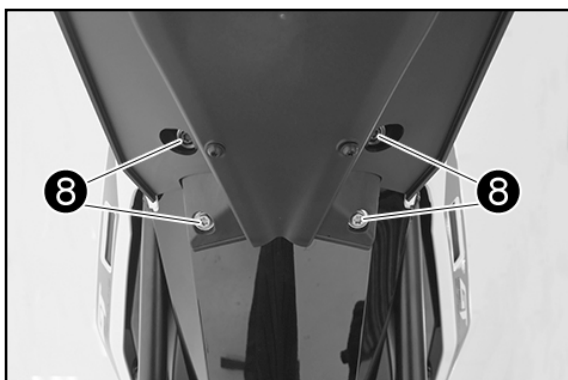

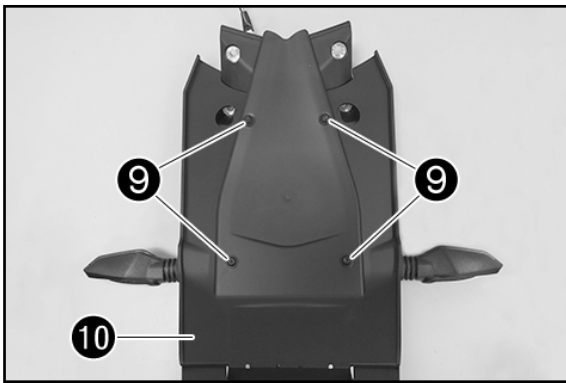

- Remove screws 9.
- Remove cover 10.

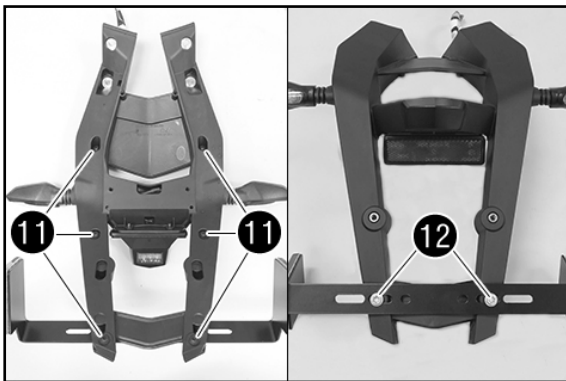

- Remove screws 11.

US models:

- Remove screws 12.
- Remove reflectors.

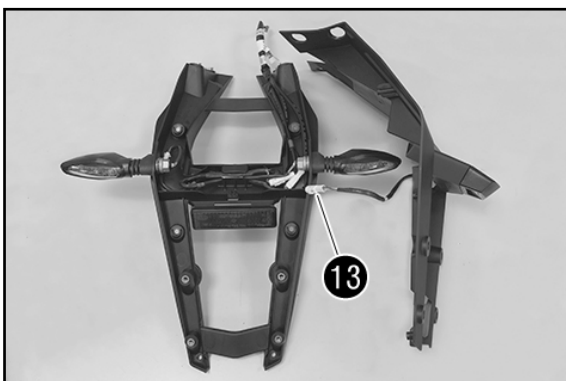

- Pull off cover.

- Slip out the cable for the license plate lighting and disconnect socket connector 13.
- Remove the cover with the license plate lighting.

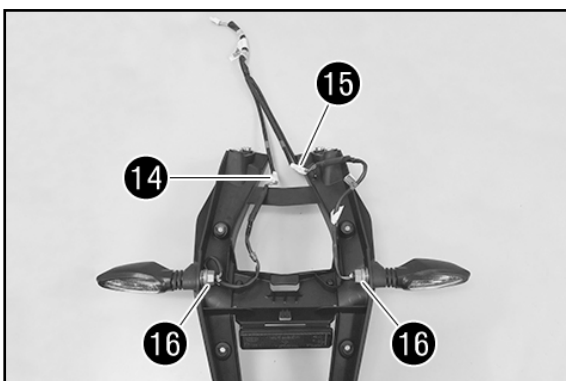

- Expose all cables.

- Disconnect turn signal socket connector left 14 and right 15.

- Loosen nuts 16 fully from thread.
- Slip out the turn signals and remove with the nuts and washers.

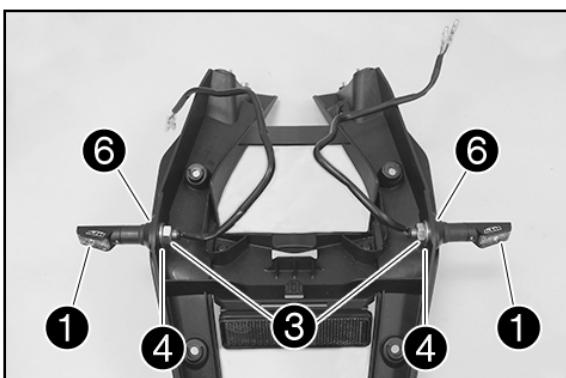

- Preassemble turn signal adapter 6 on turn signal 1 (all included).

- Thread in turn signal 1 and position with turn signal adapter 6.
- Mount nuts 3 with washers 4 (all included) and tighten.

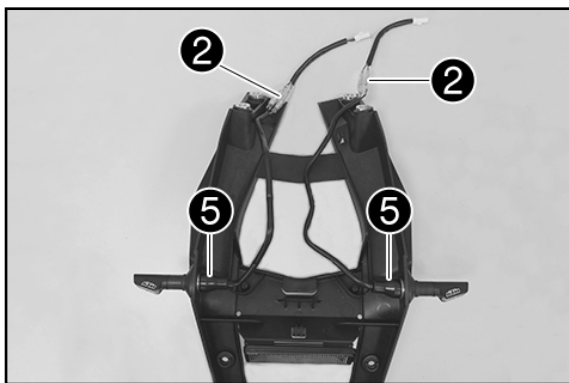

- Mount protection caps 5 (included).
- Plug in resistances 2 (included) according to the colors.

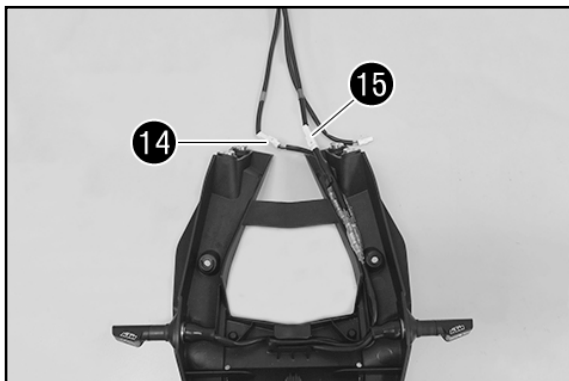

- Route all cables without tension.
- Connect turn signal socket connector left 14 and right 15.

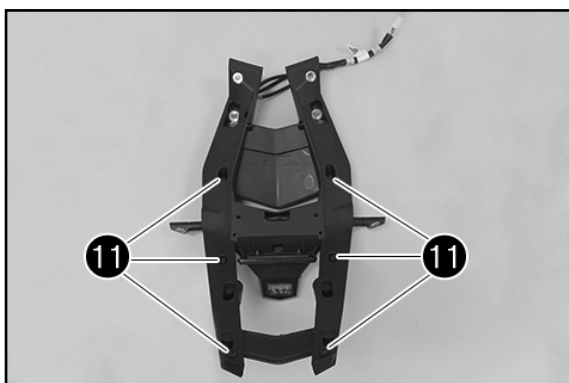

- Plug in license plate lighting 13.
- Lay the license plate lighting cable without tension.
- Position the cover.

! ATTENTION
Ensure that the cables can neither become kinked or pinched!

- Mount and firmly tighten screws 11.

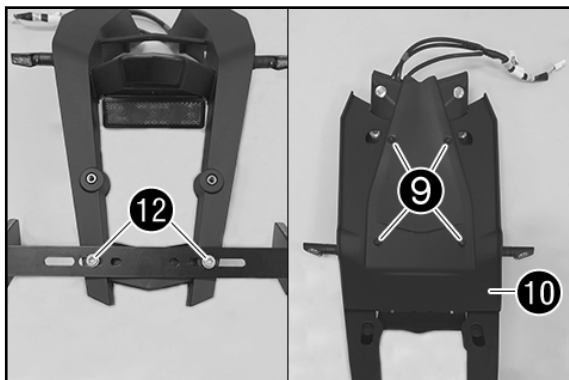

- US models:**
- Position reflectors.
 - Mount and firmly tighten screws 12.

- Position cover 10.
- Mount and tighten screws 9.

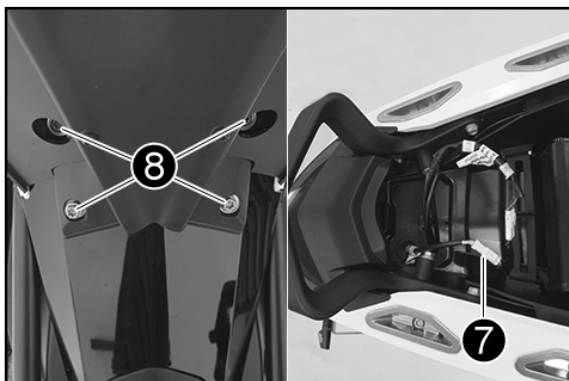

- Position the license plate holder support and thread the cable through the top.
- Mount screws 8 and tighten to 10 Nm (Loctite 243).
- Plug in socket connector 7.

Final steps

- Mount the passenger seat (see owner's manual).
- Check that the lighting is functioning properly.

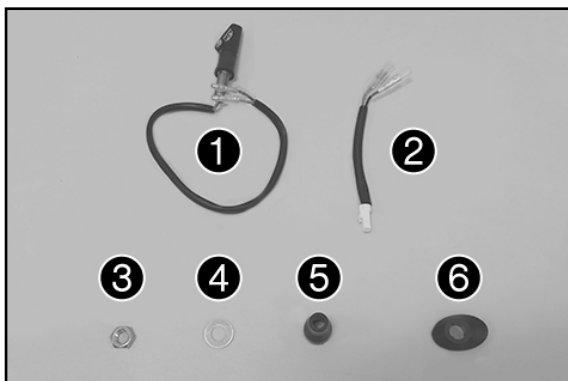

Materiale fornito

- 1 indicatore di direzione ❶
- 1 resistenza ❷
- 1 dado ❸
- 1 rondella ❹
- 1 protezione ❺
- 1 adattatore indicatori di direzione ❻

Indicatore di direzione anteriore 790 Duke

Montaggio

- Disinserire il sistema d'accensione.
- Rimuovere le viti ❷.

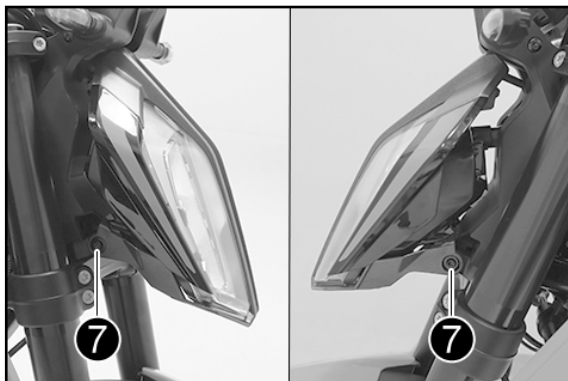

- Svitare completamente la vite di regolazione ❸.

AVVERTENZA

La vite di regolazione è fissata alla mascherina portafaro per mezzo di un supporto a testa sferica. Non estrarre la vite di regolazione dal supporto a testa sferica.

- Ruotare la mascherina portafaro leggermente in avanti e scollegare il connettore ❹.
- Rimuovere il faro.

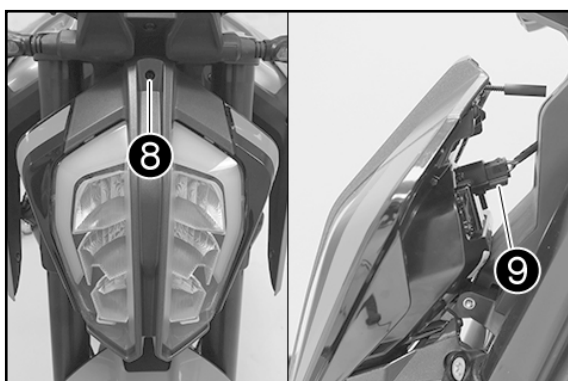

- Rimuovere le viti ❿.
- Rimuovere le viti ⓫.
- Rimuovere le viti ⓬.

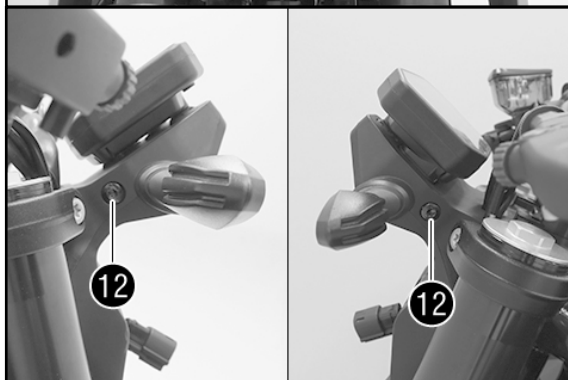
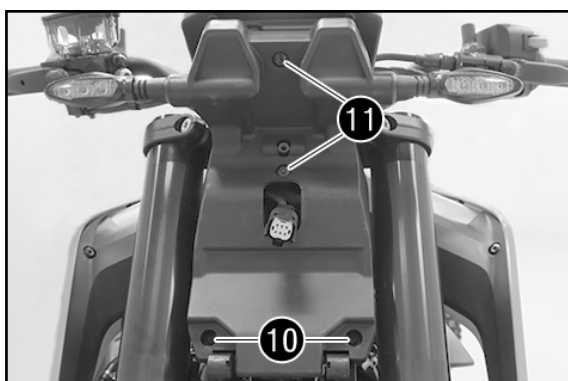

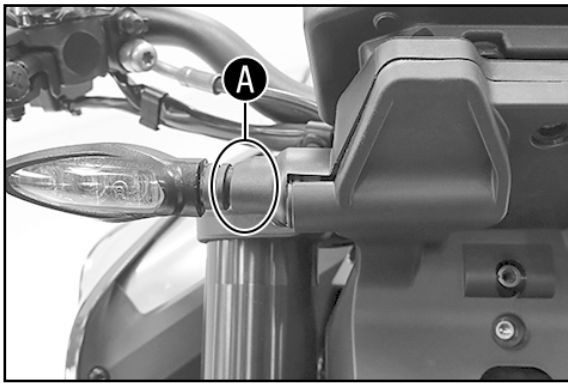

- Afferrare l'indicatore di direzione nella zona **A** e spingerlo con cautela in senso opposto alla direzione di marcia.

✓ La copertura si sgancia come si vede nella figura.

- Ripetere la fase di lavoro sul lato opposto.
- Rimuovere la copertura.

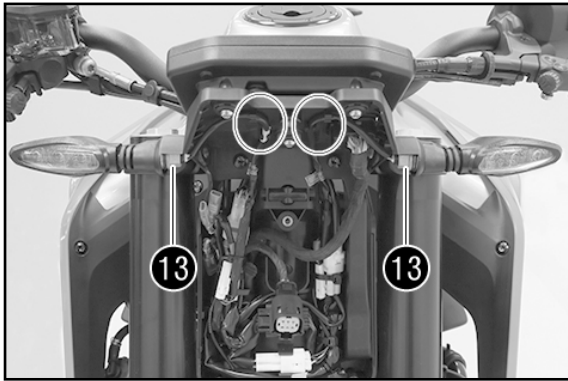

- Svitare completamente i dadi **13** dalla filettatura.
- Rimuovere il cavo dell'indicatore di direzione dai supporti in alto.

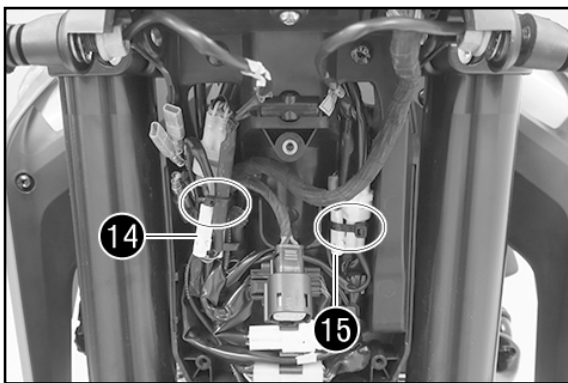

- Rimuovere le fascette serracavi.
- Staccare i connettori degli indicatori di direzione a destra **14** e a sinistra **15**.
- Rimuovere gli indicatori di direzione con i dadi e le rondelle.

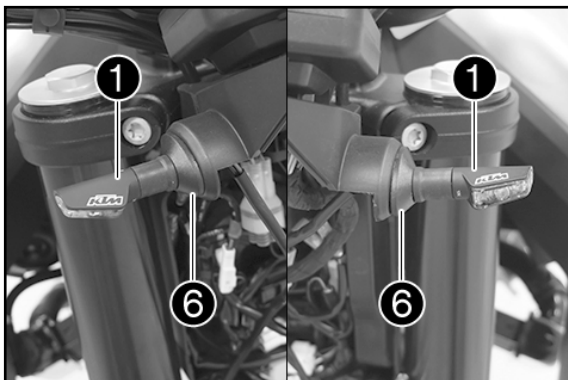

- Premontare l'adattatore indicatori di direzione **6** (in dotazione) sull'indicatore di direzione **1** (in dotazione).
- Infilare l'indicatore di direzione **1** (in dotazione) e posizionarlo con l'adattatore indicatori di direzione **6**.

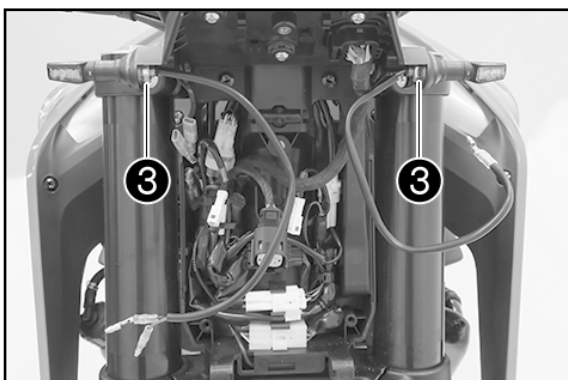

- Montare e serrare i dadi **3** con rondelle **4** (tutto in dotazione).

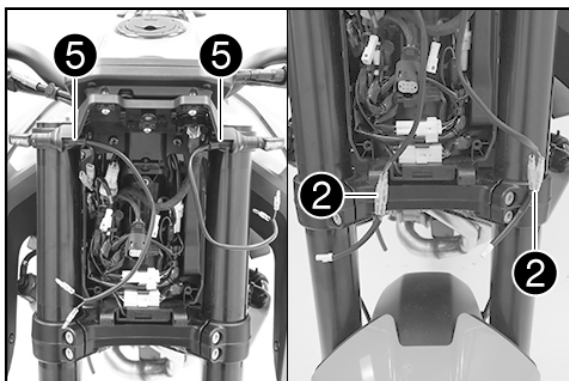

- Montare le protezioni ⑤ (in dotazione).
- Collegare le resistenze ② (in dotazione) in base ai colori.

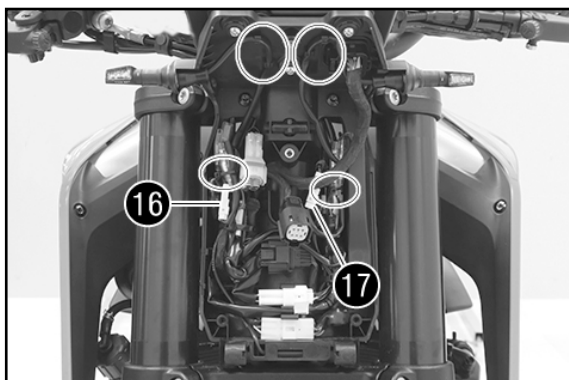

- Collegare i connettori degli indicatori di direzione ⑯ e ⑰.
- Montare il cavo dell'indicatore di direzione nei supporti in alto.
- Posare tutti i cavi in modo che non presentino punti in tensione e assicurarli con una fascetta serracavi.

! AVVERTIMENTO

Assicurarsi che il cavo non rischi di venire piegato o bloccato in qualche modo!

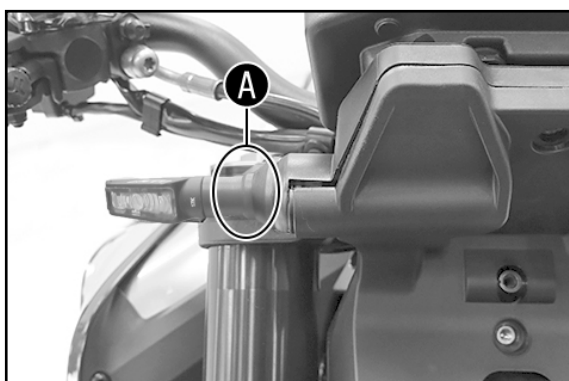

- Posizionare la copertura e far passare il connettore del faro attra verso l'apertura.
- Afferrare l'indicatore di direzione nella zona ① e spingerlo con cautela in senso opposto alla direzione di marcia, contemporaneamente premere in sede la copertura.

✓ La copertura si innesta con un clic udibile.

- Ripetere la fase di lavoro sul lato opposto.

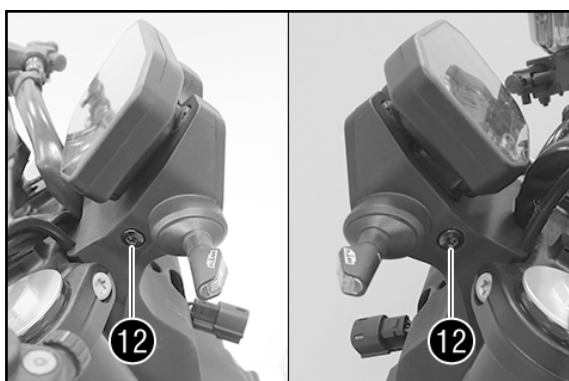

- Montare le viti ⑫ e serrarle a 5 Nm.
- Montare le viti ⑪ e serrarle a 5 Nm.
- Montare le viti ⑩ e serrarle a 2 Nm.

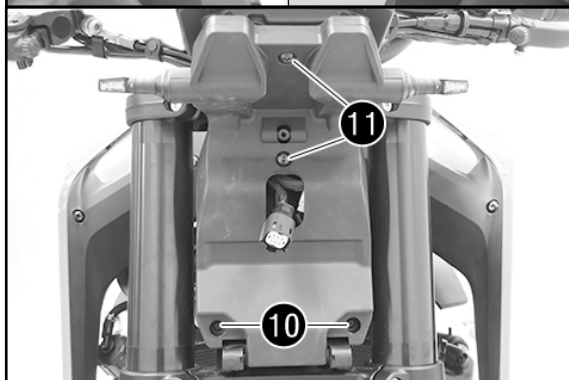

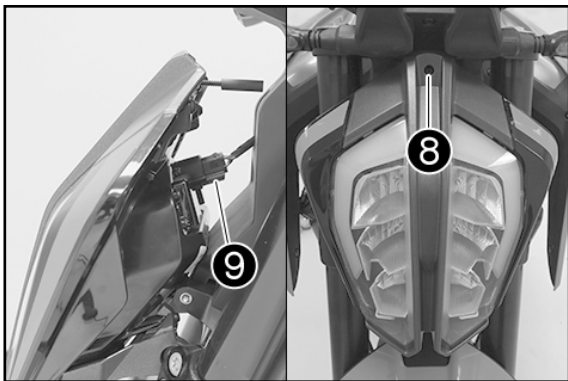

- Collegare il connettore 9.
- Posizionare la mascherina portafaro.
- Montare la vite di regolazione 8.

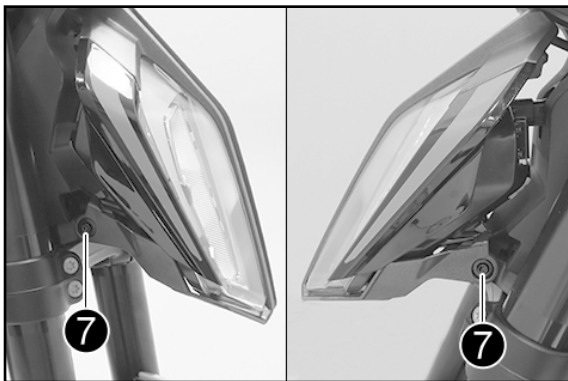

- Montare le viti 7 e serrarle a 2 Nm.

Operazione conclusiva

- Controllare l'orientamento del faro (v. manuale d'uso).
- Regolare la profondità del fascio luminoso del faro (v. manuale d'uso).
- Controllare il funzionamento dell'illuminazione.

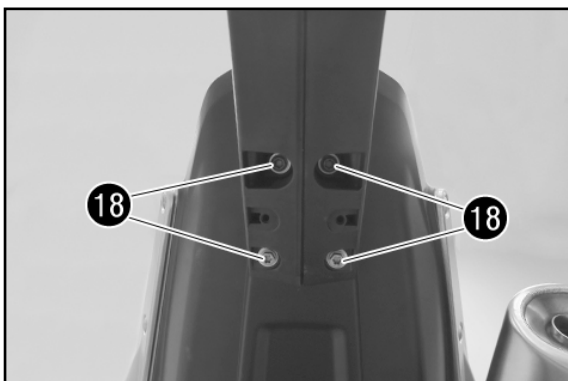

Indicatori di direzione posteriori 790 Duke

Montaggio

- Rimuovere le viti 18.
- Appoggiare il portatarga sulla ruota posteriore.

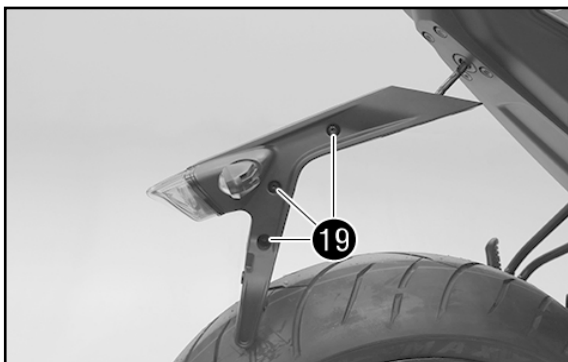

- Rimuovere le viti 19.
- Ruotare verso l'esterno le due metà del portatarga e disimpegnarle nella zona B.
- Appoggiare la luce di posizione posteriore sulla ruota posteriore.

AVVERTENZA

In base alle necessità è possibile rimuovere l'intero portatarga. A tale scopo scollegare il rispettivo connettore sotto la sella del passeggero e sfilare il cavo con il passacavo in gomma.

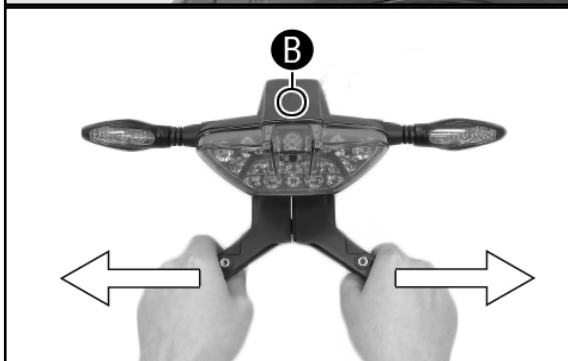

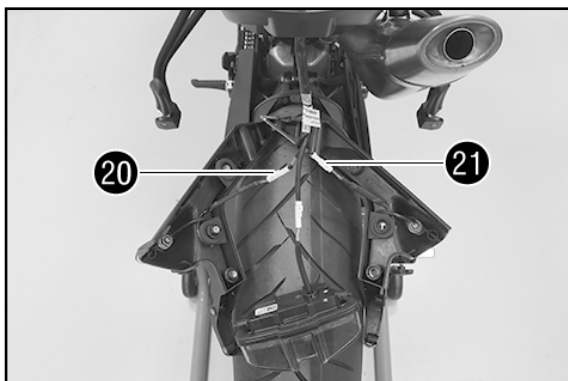

- Scollegare il connettore dell'indicatore di direzione 20 e 21.
- Rimuovere le due metà del portatarga.

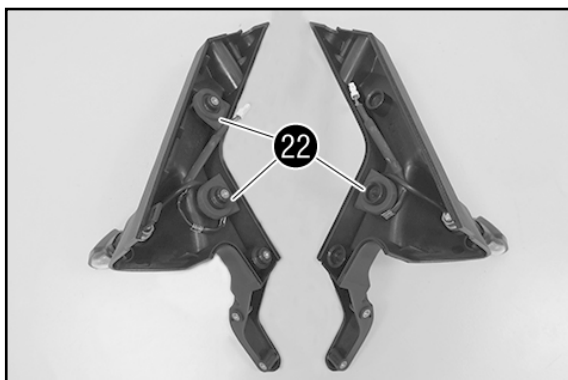

- Rimuovere il portacavo 22.

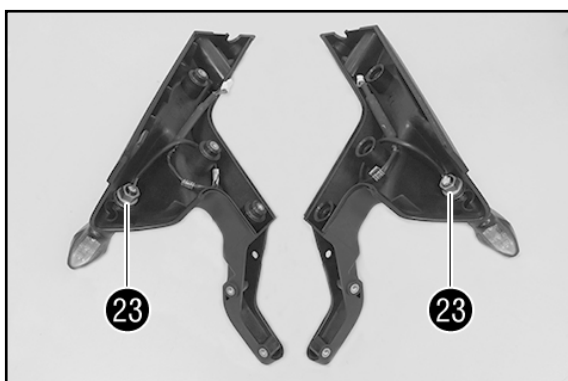

- Rimuovere i dadi 23 con le rondelle.
- Rimuovere l'indicatore di direzione.

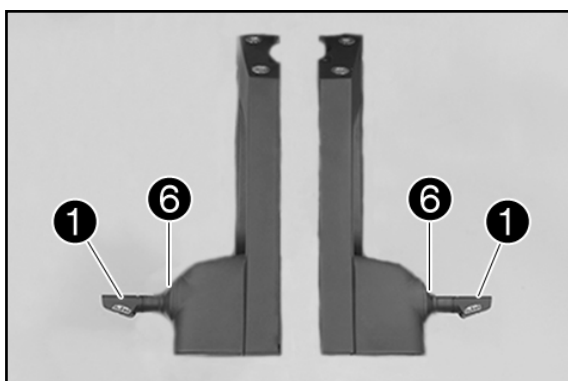

- Premontare l'adattatore indicatori di direzione 6 (in dotazione) sull'indicatore di direzione 1 (in dotazione).
- Infilare l'indicatore di direzione 1 (in dotazione) e posizionarlo con l'adattatore indicatori di direzione 6.

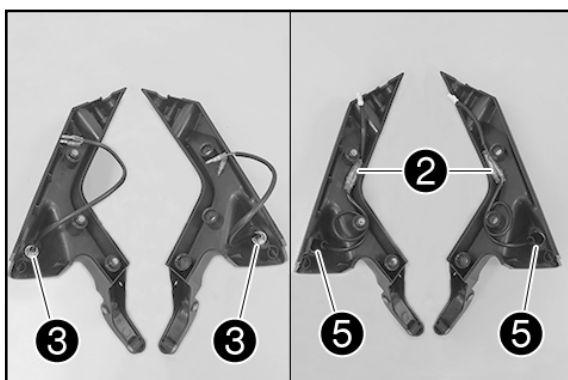

- Montare e serrare i dadi 3 con rondelle 4 (tutto in dotazione).
- Montare le protezioni 5 (in dotazione).
- Collegare le resistenze 2 (in dotazione) in base ai colori.
- Posizionare il cavo.

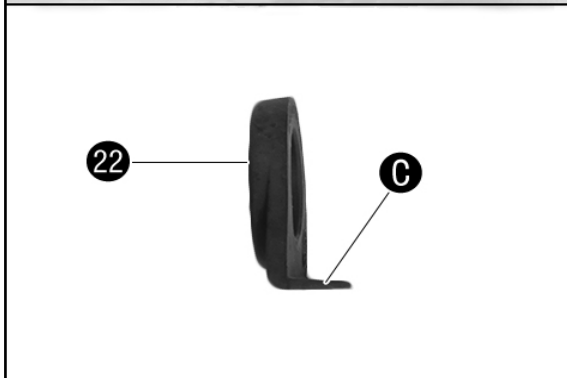
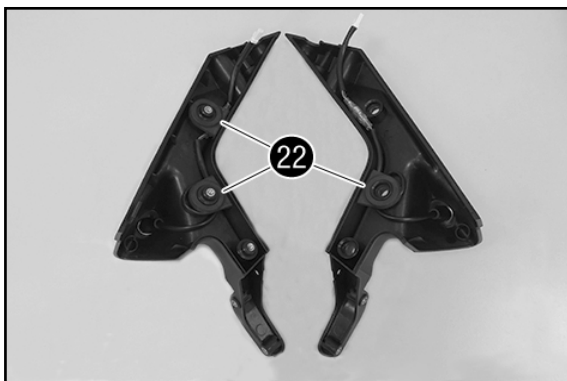

- Montare il portacavo 22 con il labbro C rivolto all'interno.

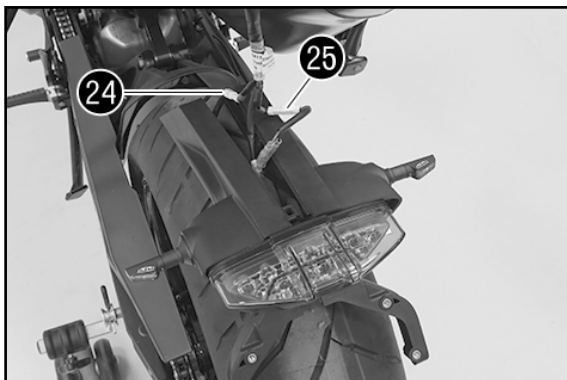

- Collegare il connettore dell'indicatore di direzione 24 e 25.
 - Posizionare le due metà del portatarga sulla luce di posizione posteriore.
 - Posizionare il cavo prestando attenzione a non metterlo in tensione.

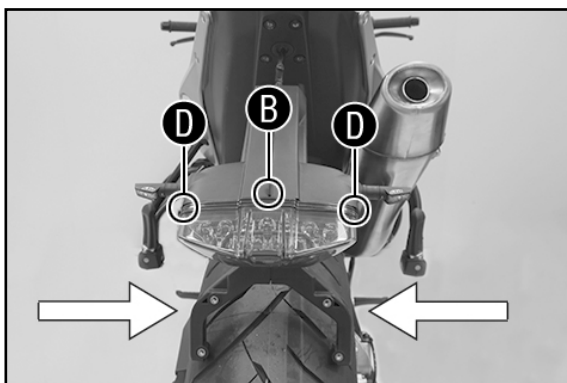

- Innestare le due metà del portatarga nella zona B e agganciare la luce di posizione posteriore nelle zone D.
 - Ricollegare le due metà del portatarga.

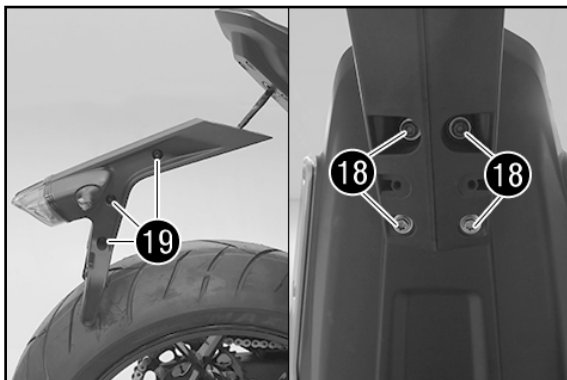

- Montare le viti 19 e serrarle a 5 Nm.
 - Posizionare il portatarga.
 - Montare le viti 18 e serrarle a 10 Nm (Loctite 243).

Operazione conclusiva

- Controllare il funzionamento dell'illuminazione.

Freccia anteriore 1290 Duke R

Montaggio

- Disinserire il sistema d'accensione.
- Svitare completamente la vite di regolazione 7.

AVVERTENZA

La vite di regolazione è fissata alla mascherina portafaro per mezzo di un supporto a testa sferica.

Non estrarre la vite di regolazione dal supporto a testa sferica.

- Ruotare la mascherina portafaro leggermente in avanti e se necessario scollegare il connettore 8.

- Rimuovere le viti 9.
- Rimuovere la vite 10.

- Afferrare la freccia nella zona A e spingerla delicatamente in senso opposto alla direzione di marcia.

✓ Il coperchio si stacca.

- Rimuovere il coperchio tirandolo verso l'alto.

- Svitare completamente i dadi 11 dalla filettatura.
- Rimuovere la fascetta serracavi.

- Scollegare il connettore della freccia di destra 12 e sinistra 13.
- Sfilare le frecce e rimuoverle con dadi e rondelle.

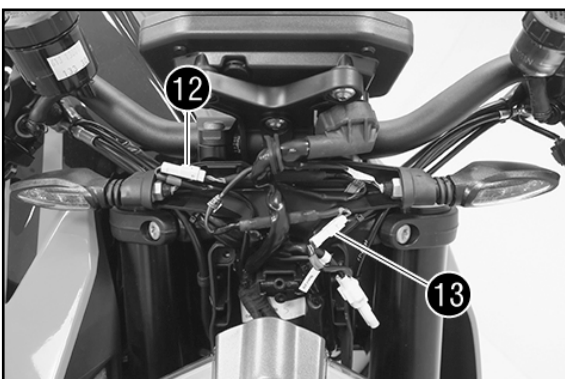
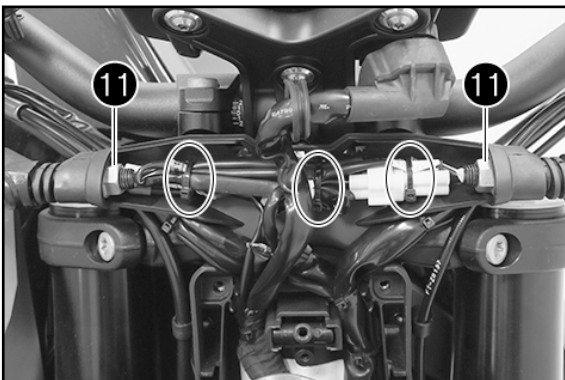
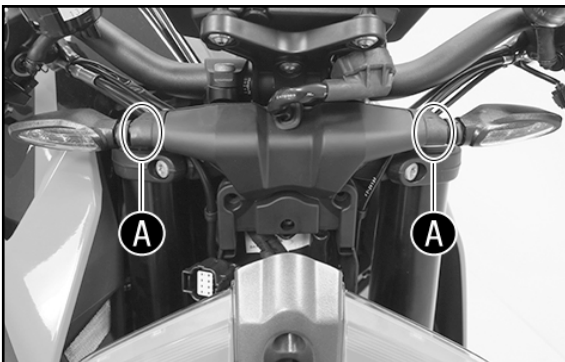
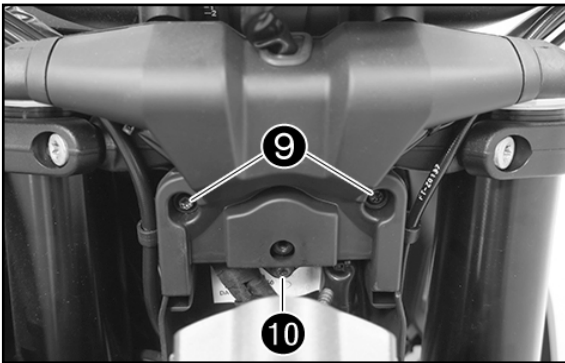

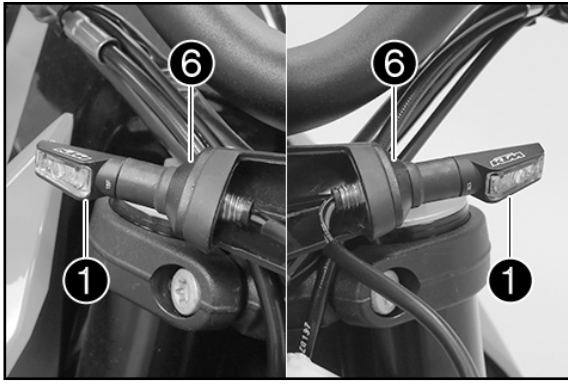

- Premontare l'adattatore ❹ (in dotazione) sulla freccia ❶ (in dotazione).
- Infilare la freccia ❶ (in dotazione) e posizionarla con l'adattatore ❹.

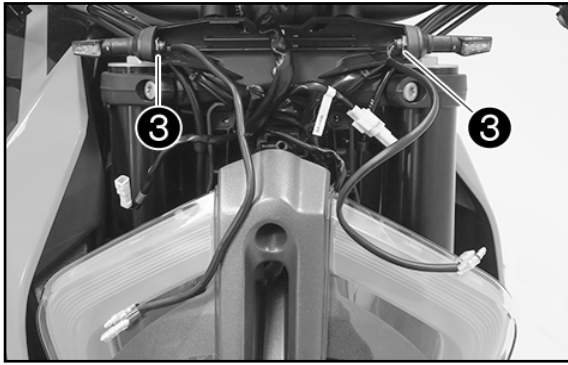

- Montare e serrare i dadi ❸ con rondelle ❺ (tutto in dotazione).

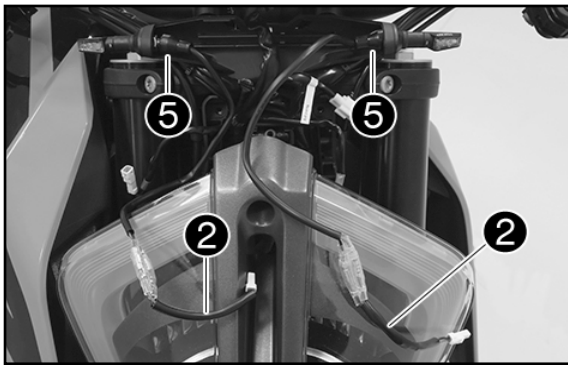

- Montare le protezioni ❽ (in dotazione).
- Collegare le resistenze ❷ (in dotazione) in base ai colori.

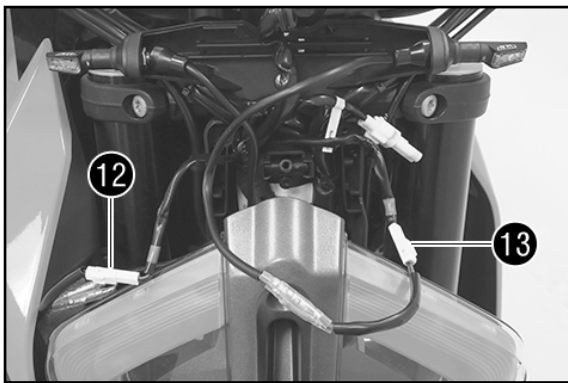

- Collegare il connettore della freccia di destra ❿ e sinistra ⓫.

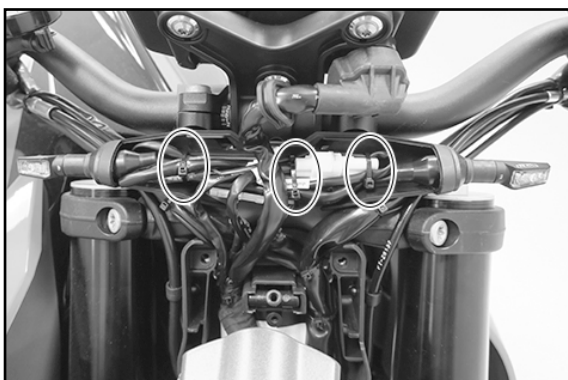

- Posare tutti i cavi in modo che non presentino punti in tensione e assicurarli con una fascetta serracavi.

! AVVERTIMENTO

Assicurarsi che il cavo non rischi di venire piegato o bloccato in qualche modo!



- Posizionare il coperchio e il cavo con il passacavo in gomma.
 - Afferrare la freccia nella zona **A** e spingerla delicatamente in senso opposto alla direzione di marcia.
Contemporaneamente premere in sede il coperchio.
- ✓ Il coperchio si innesta con un clic udibile.

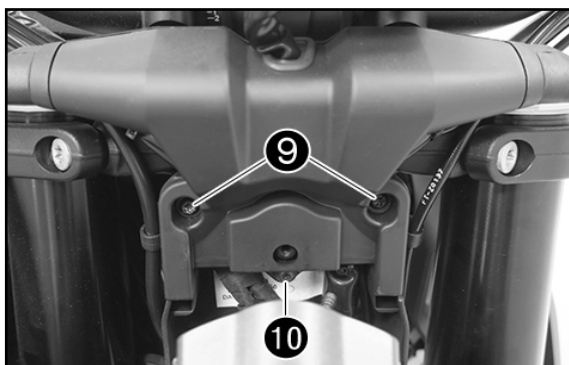

- Montare le viti **9** e serrarle a 5 Nm.
- Montare la vite **10** e serrarla a 5 Nm.

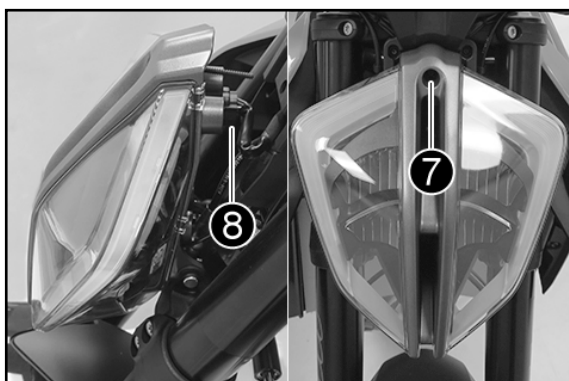

- Se necessario collegare il connettore **8**.
- Posizionare la mascherina portafaro.
- Montare la vite di regolazione **7**.

Operazione conclusiva

- Controllare l'orientamento del faro (v. manuale d'uso).
- Regolare la profondità del fascio luminoso del faro (v. manuale d'uso).
- Controllare il funzionamento dell'illuminazione.

Freccia posteriore 1290 Super Duke R

Operazione preliminare

- Rimuovere la sella del passeggero (v. il manuale d'uso).

Montaggio

- Scollegare il connettore **14**.
- Rimuovere le viti **15**.
- Rimuovere il portatarga.

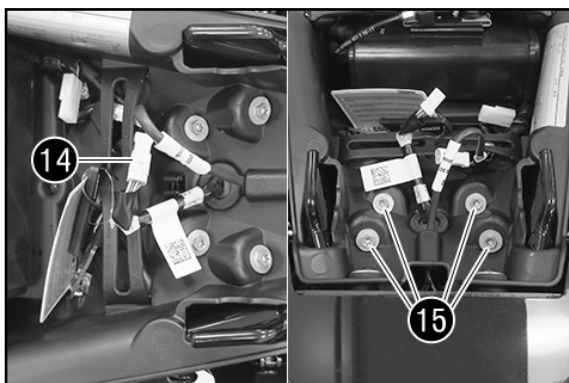

- Rimuovere le viti **16**.
- Rimuovere le viti **17**.

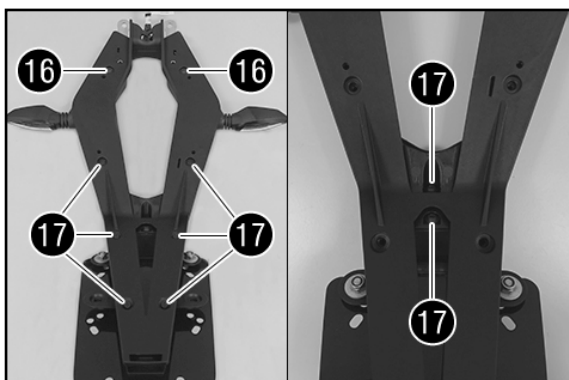

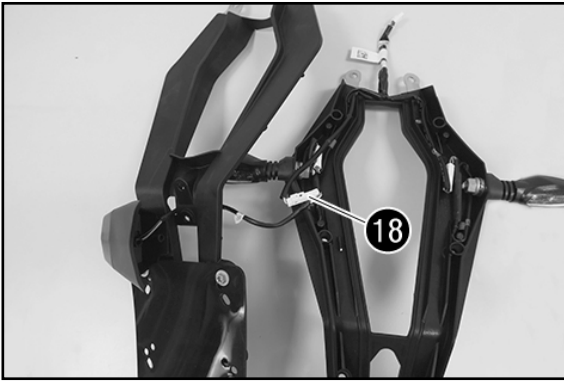

- Staccare il coperchio.
- Sfilare il cavo della luce della targa e scollegare il connettore 18.
- Rimuovere il coperchio con la luce della targa.

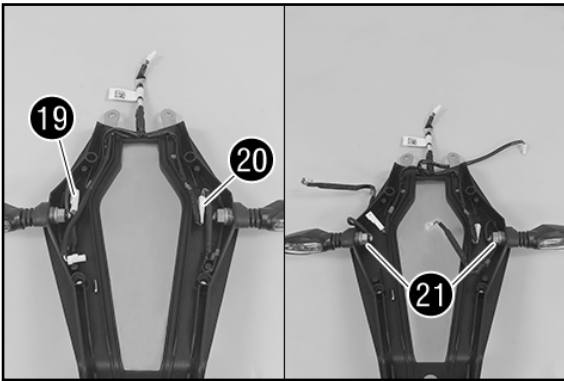

- Scoprire tutti i cavi.
- Scollegare il connettore della freccia di sinistra 19 e destra 20.
- Svitare completamente i dadi 21 dalla filettatura.
- Sfilare le frecce e rimuoverle con dadi e rondelle.

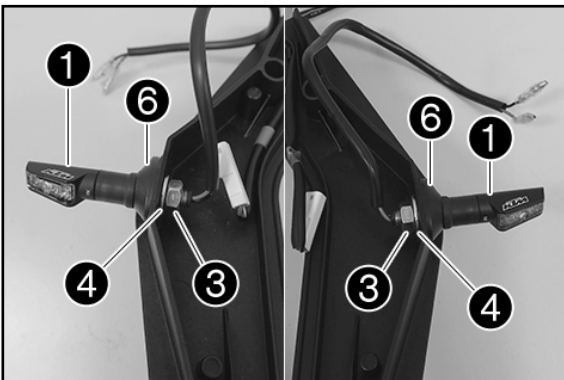

- Premontare l'adattatore della freccia 6 sulla freccia 1 (tutto in dotazione).
- Con un utensile adatto praticare i fori di montaggio per l'adattatore della freccia 6.
- Infilare la freccia 1 e posizionarla con il relativo adattatore 6.
- Montare e serrare i dadi 3 con rondelle 4 (tutto in dotazione).

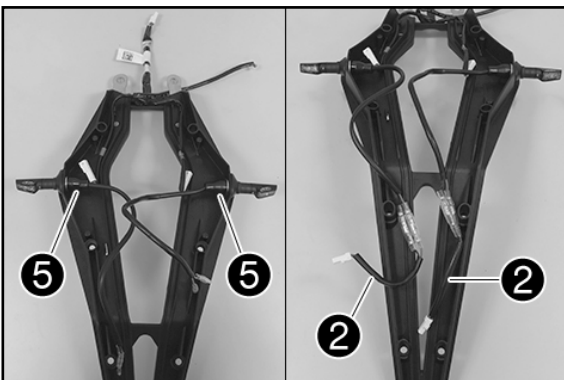

- Montare le protezioni 5 (in dotazione).
- Collegare le resistenze 2 (in dotazione) in base ai colori.

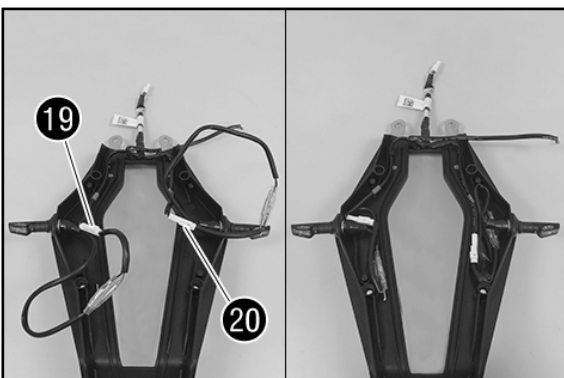

- Collegare il connettore della freccia di sinistra 19 e destra 20.
- Posare tutti i cavi in modo che non siano in tensione.

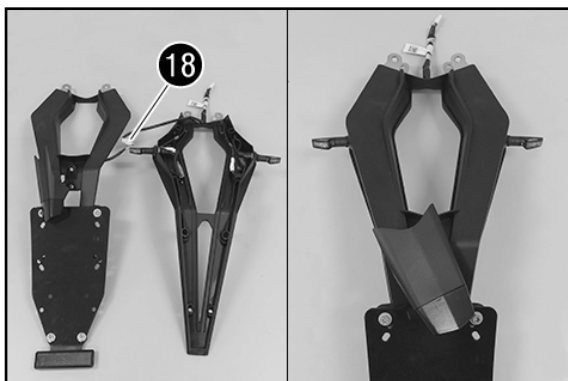

- Collegare il connettore della luce della targa 18.

- Posizionare il coperchio.
- Posare il cavo della luce della targa in modo che non presenti punti in tensione.

! AVVERTIMENTO

Assicurarsi che i cavi non rischino di venire piegati o bloccati in qualche modo!

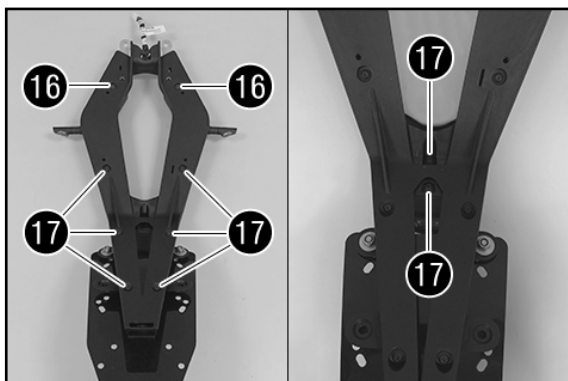

- Montare le viti 16 senza però serrarle.
- Montare le viti 17, senza però serrarle.

- Posizionare la luce della targa e montare e serrare le viti 17.
- Serrare tutte le viti 16 e 17.

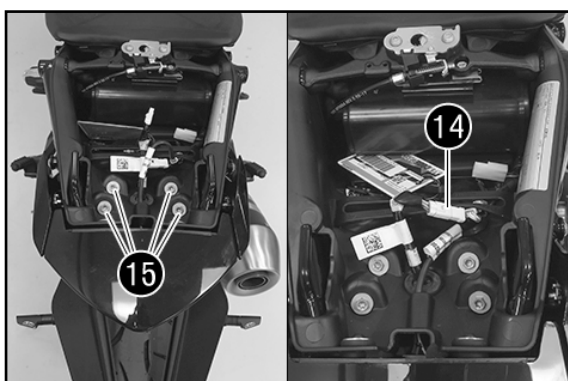

- Posizionare il portatarga e far passare il cavo attraverso la parte superiore.
- Montare le viti 15 e serrarle a 10 Nm (Loctite 243).
- Collegare il connettore 14.

Operazione conclusiva

- Montare la sella del passeggero (v. il manuale d'uso).
- Controllare il funzionamento dell'illuminazione.



Freccia posteriore 1290 Super Duke GT

Operazione preliminare

- Rimuovere la sella del passeggero (v. il manuale d'uso).

Montaggio

- Staccare il connettore 7.

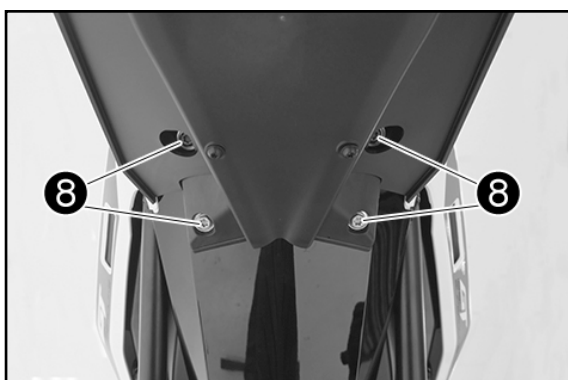

- Rimuovere le viti 8.
- Rimuovere il portatarga.

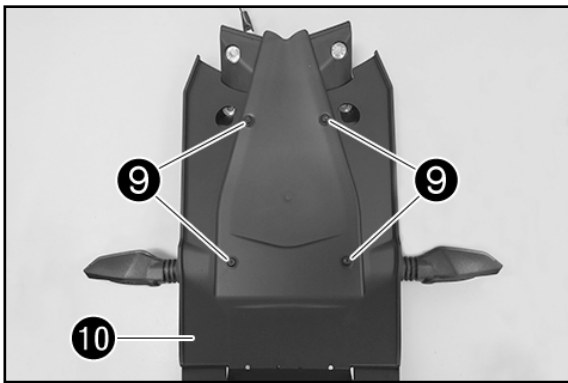

- Rimuovere le viti 9.
- Rimuovere il coperchio 10.

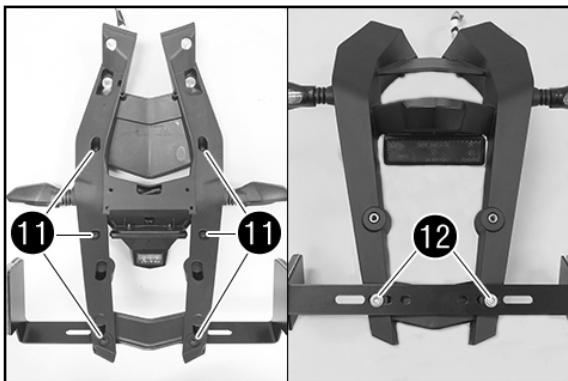

- Rimuovere le viti 11.

Modelli americani:

- Rimuovere le viti 12.
- Rimuovere i riflettori.

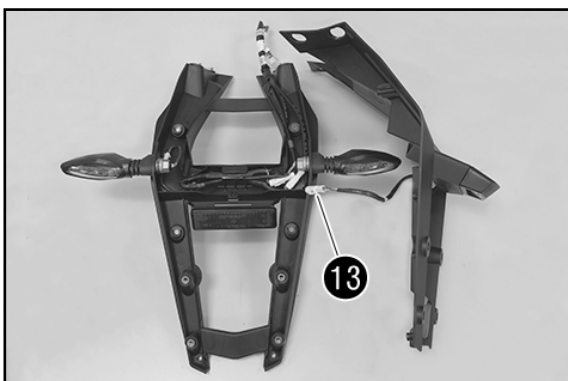

- Staccare il coperchio.

- Sfilare il cavo della luce della targa e scollegare il connettore 13.
- Rimuovere il coperchio con la luce della targa.

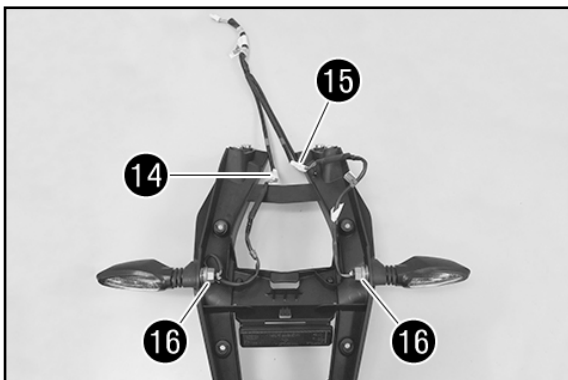

- Scoprire tutti i cavi.
- Scollegare il connettore della freccia di sinistra 14 e destra 15.

- Svitare completamente i dadi 16 dalla filettatura.
- Sfilare le frecce e rimuoverle con dadi e rondelle.

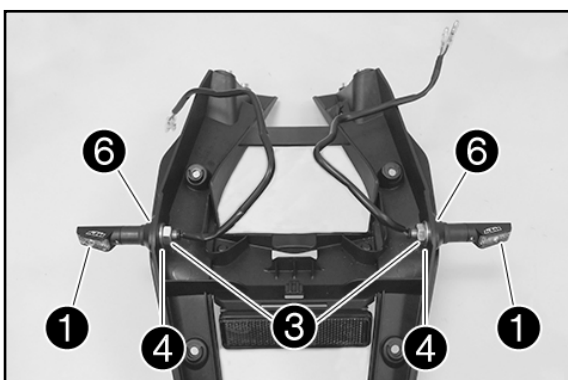

- Premontare l'adattatore della freccia 6 sulla freccia 1 (tutto in dotazione).

- Infilare la freccia 1 e posizionarla con il relativo adattatore 6.
- Montare e serrare i dadi 3 con rondelle 4 (tutto in dotazione).

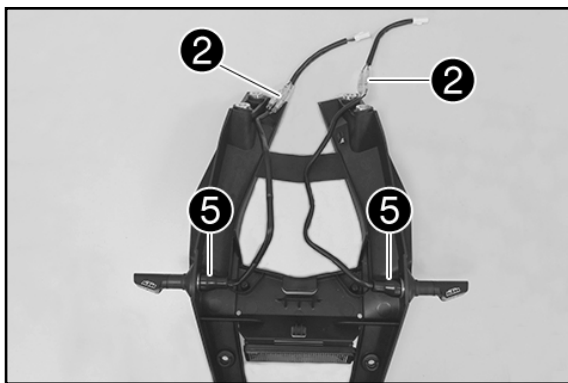

- Montare le protezioni ⑤ (in dotazione).
- Collegare le resistenze ② (in dotazione) in base ai colori.

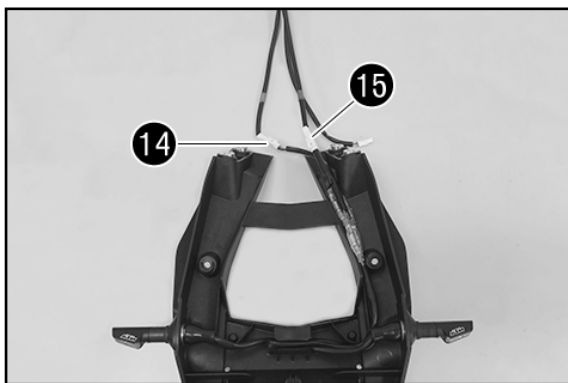

- Posare tutti i cavi in modo che non siano in tensione.
- Collegare il connettore della freccia di sinistra ⑭ e destra ⑮.

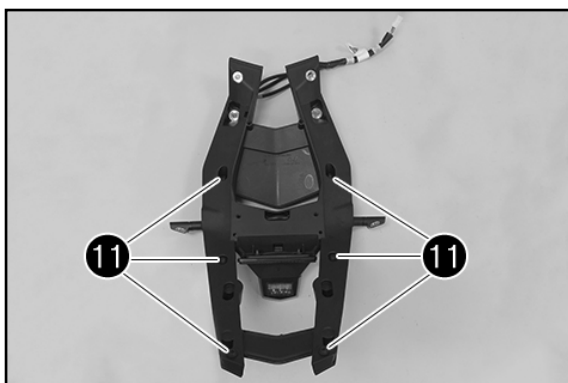

- Collegare il connettore della luce della targa ⑬.
- Posare il cavo della luce della targa in modo che non presenti punti in tensione.
- Posizionare il coperchio.

! AVVERTIMENTO

Assicurarsi che i cavi non rischino di venire piegati o bloccati in qualche modo!

- Montare e serrare le viti ⑪.

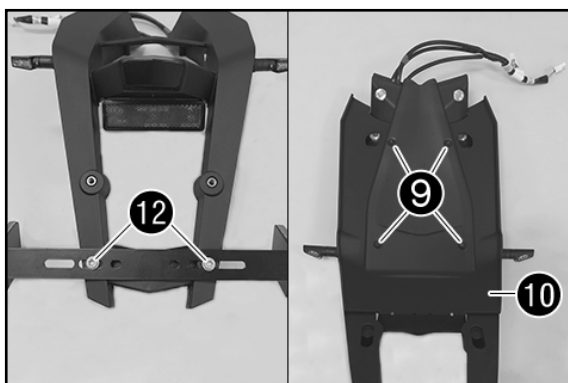

Modelli americani:

- Posizionare i riflettori.
- Montare e serrare le viti ⑫.

- Posizionare il coperchio ⑩.
- Montare e serrare le viti ⑨.

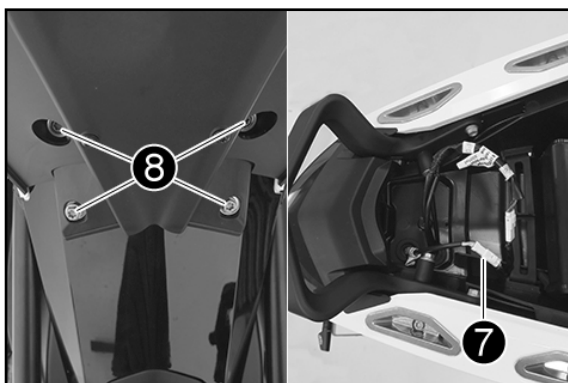

- Posizionare il portatarga e far passare il cavo attraverso la parte superiore.
- Montare le viti ⑧ e serrare a 10 Nm (Loctite 243).
- Collegare il connettore ⑦.

Operazione conclusiva

- Montare la sella del passeggero (v. il manuale d'uso).
- Controllare il funzionamento dell'illuminazione.

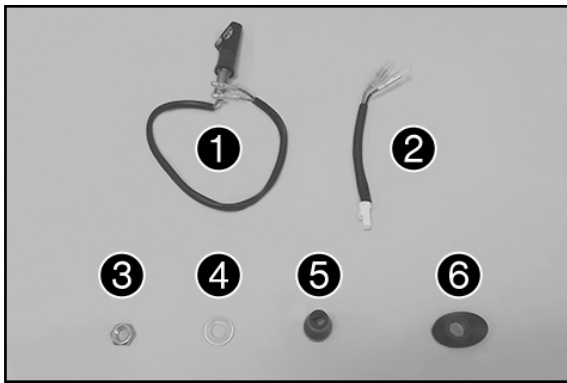

Contenu de la livraison

- 1x clignotant ❶
- 1x résistance ❷
- 1x écrou ❸
- 1x rondelle ❹
- 1x capuchon ❺
- 1x adaptateur de clignotant ❻

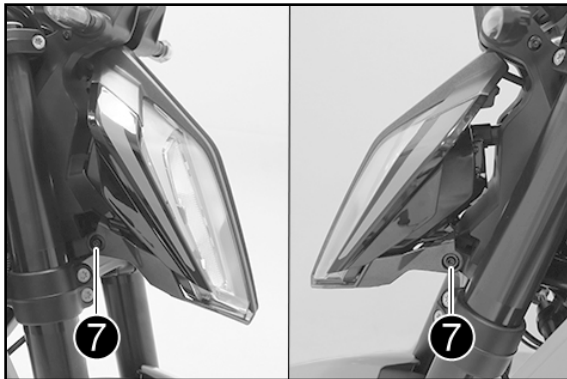

Clignotant avant 790 Duke

Montage

- Couper le contact.
- Retirer les vis ❷.

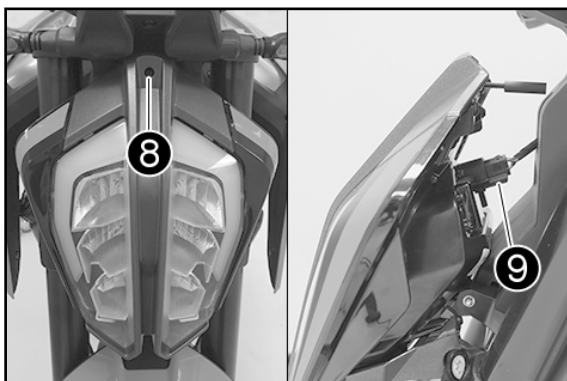

- Dévisser complètement la vis de réglage ❸.

REMARQUE

La vis de réglage est maintenue sur la plaque-phare par une fixation à tête de rotule.
Ne pas retirer la vis de réglage de la fixation à tête de rotule.

- Basculer la plaque-phare légèrement vers l'avant et débrancher le connecteur ❹.
- Déposer le phare.

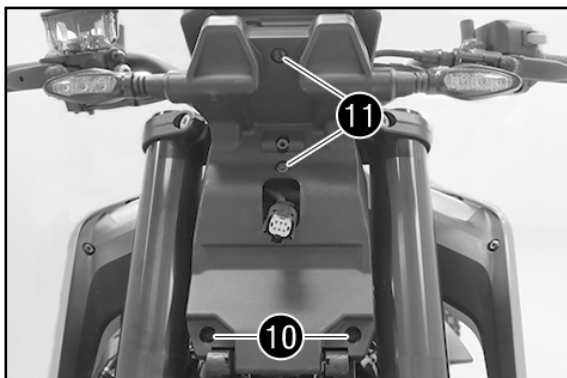

- Retirer les vis ❿.
- Retirer les vis ⓫.
- Retirer les vis ⓬.

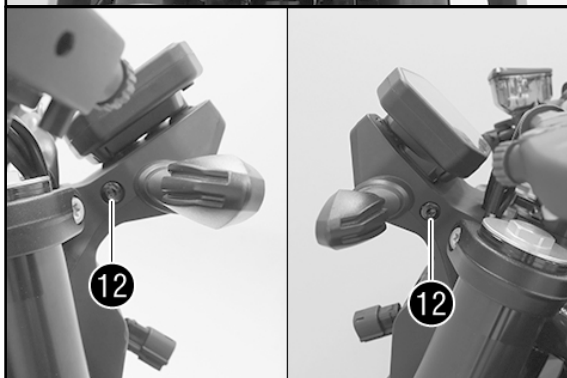

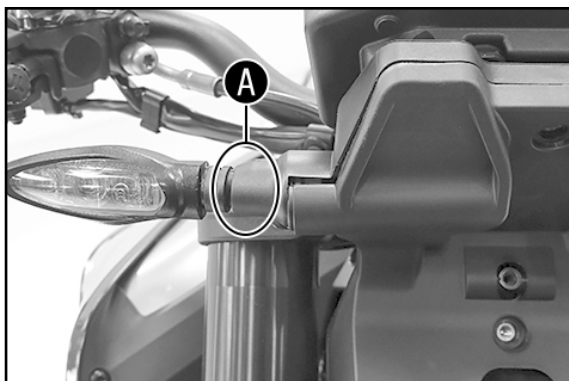

- Saisir le clignotant dans la zone **A** et appuyer avec précaution dans la direction opposée au sens de marche.

✓ Le cache se détache comme indiqué sur la figure.

- Répéter l'étape de travail du côté opposé.
- Déposer le cache.

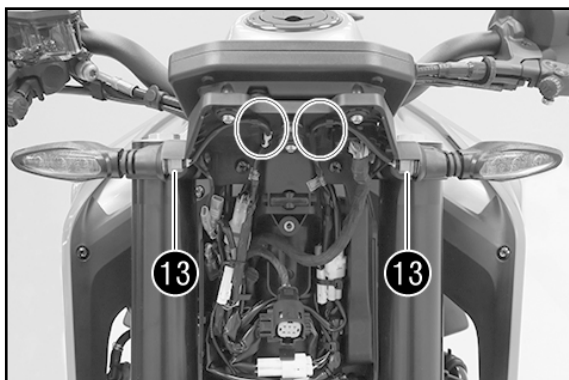

- Desserrer complètement les écrous **13** du filetage.
- Retirer le câble du clignotant des supports supérieurs.

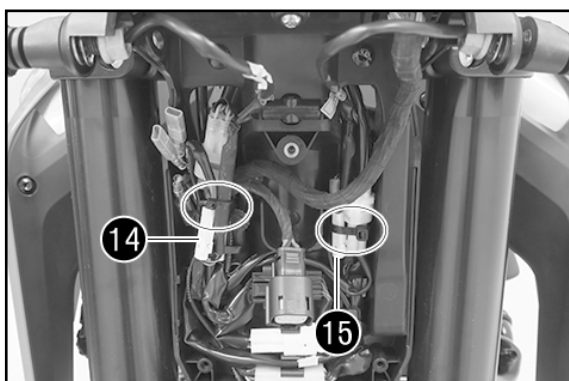

- Retirer le rilsan.
- Débrancher les connecteurs du clignotant droit **14** et gauche **15**.
- Retirer le clignotant ainsi que les écrous et les disques.

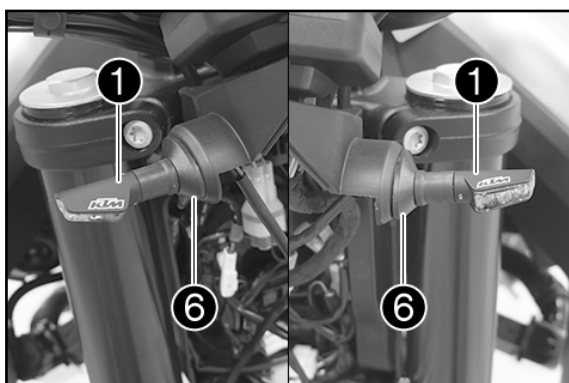

- Prémonter l'adaptateur de clignotant **6** (contenu de la livraison) sur le clignotant **1** (contenu de la livraison).
- Enfiler le clignotant **1** (contenu de la livraison) et le positionner avec l'adaptateur de clignotant **6**.

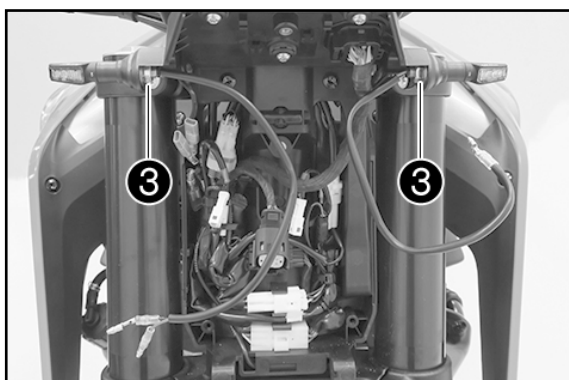

- Mettre en place les écrous **3** avec les rondelles **4** (tous compris dans la livraison) et les serrer.

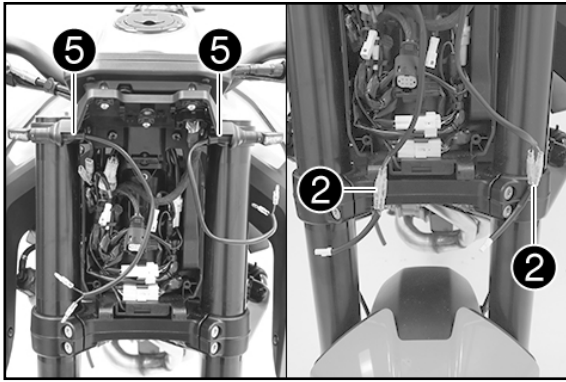

- Mettre en place les capuchons ⑤ (contenu de la livraison).
- Brancher les résistances ② (contenu de la livraison) en respectant les couleurs.

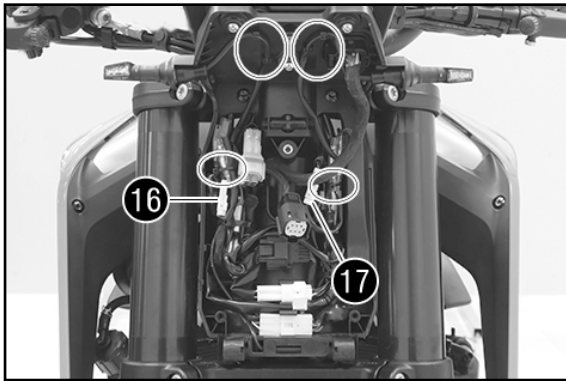

- Brancher les connecteurs du clignotant ⑩ et ⑪.
- Mettre en place le câble du clignotant dans les supports supérieurs.
- Poser tous les câbles de manière à ce qu'ils ne soient soumis à aucune contrainte et les bloquer à l'aide d'un serre-câbles.

! ATTENTION

Veiller à ce que le câble ne soit ni plié ni coincé !

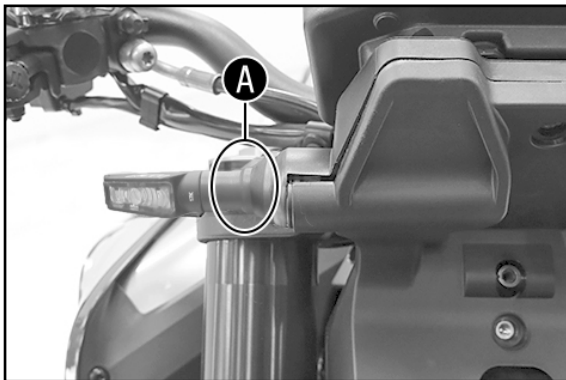

- Positionner le cache en faisant passer le connecteur du phare par l'ouverture.
- Saisir le clignotant dans la zone A et appuyer avec précaution dans la direction opposée au sens de marche tout en appuyant fermement sur le cache.

✓ L'emboîtement du cache est perceptible à l'oreille.

- Répéter l'étape de travail du côté opposé.

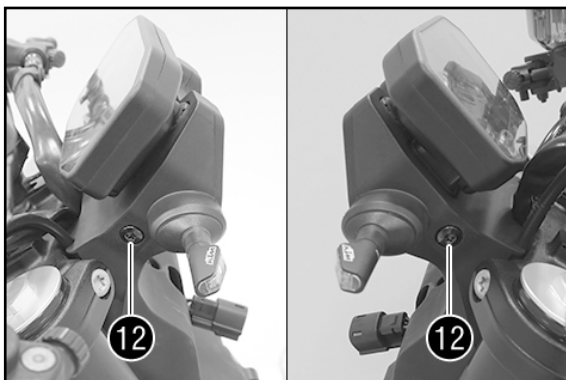

- Mettre en place les vis ⑫ et les serrer à 5 Nm.
- Mettre en place les vis ⑪ et les serrer à 5 Nm.
- Mettre en place les vis ⑩ et les serrer à 2 Nm.

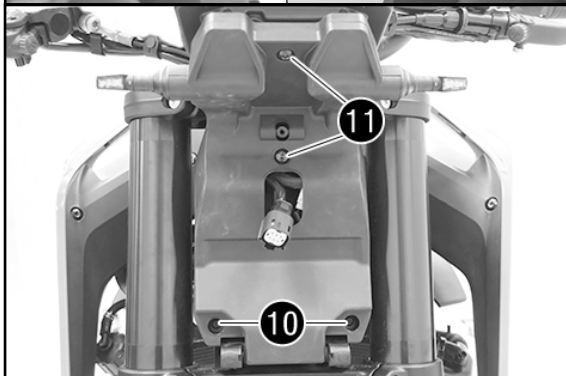

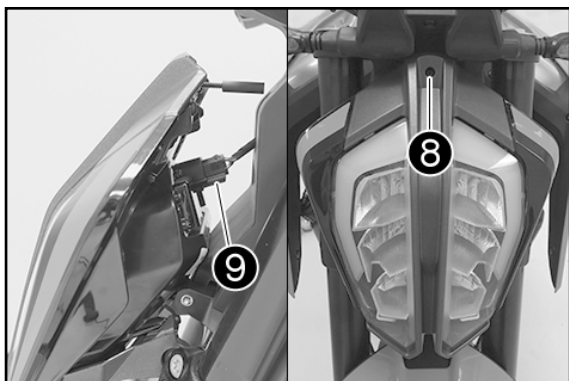

- Brancher le connecteur ⑨.
- Positionner la plaque-phare.
- Mettre en place la vis de réglage ⑧.

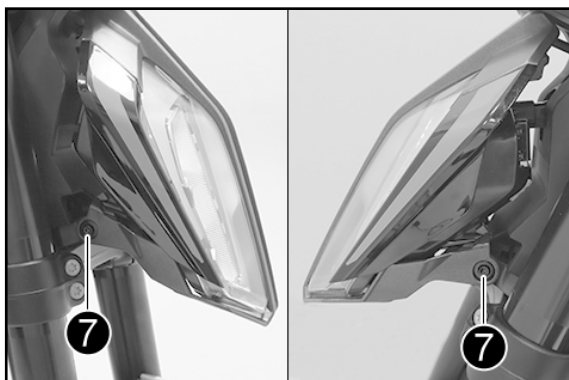

- Mettre les vis ⑦ en place et les serrer à 2 Nm.

Travaux ultérieurs

- Contrôler le réglage du phare (voir le manuel d'utilisation).
- Régler la portée du phare (voir le manuel d'utilisation).
- Contrôler le fonctionnement de l'éclairage.

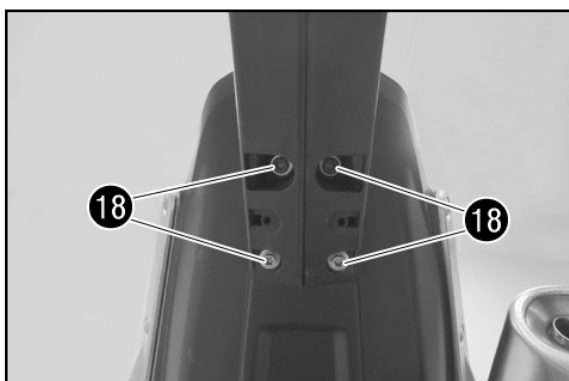

Clignotant arrière 790 Duke

Montage

- Retirer les vis ⑱.
- Déposer le support de plaque d'immatriculation sur la roue arrière.

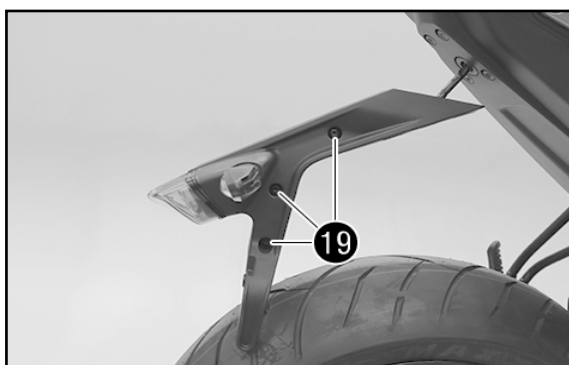

- Retirer les vis ⑲.
- Pivoter les demi porte-plaque vers l'extérieur et les décrocher au niveau de l'emplacement ⑱.
- Déposer le feu arrière sur la roue arrière.

REMARQUE

Au besoin, il est possible de retirer le support de plaque d'immatriculation complet. Pour cela, débrancher le connecteur correspondant situé sous la selle passager et dégager le câble avec la gaine en caoutchouc.

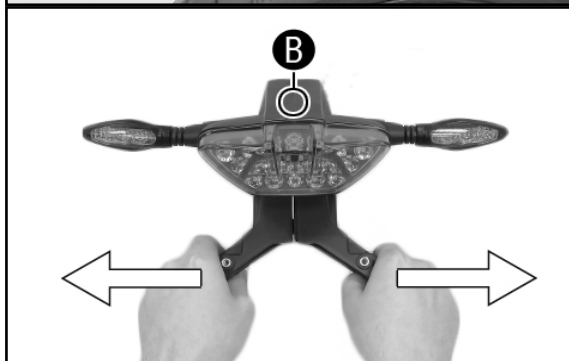

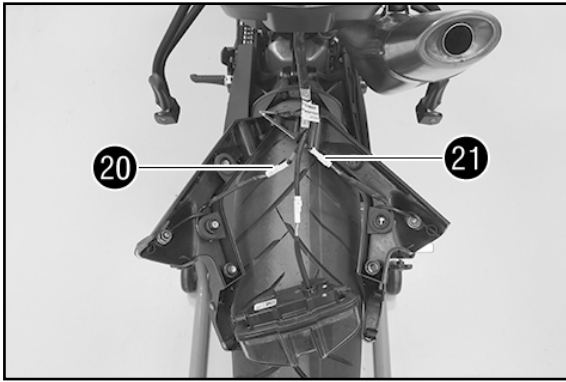

- Débrancher les connecteurs 20 et 21 du clignotant.
- Déposer les demi porte-plaque.

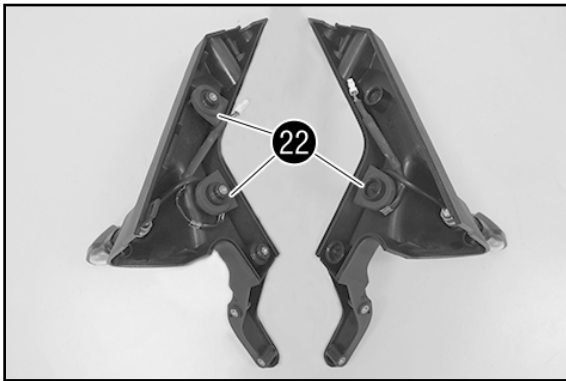

- Retirer le support de câble 22.

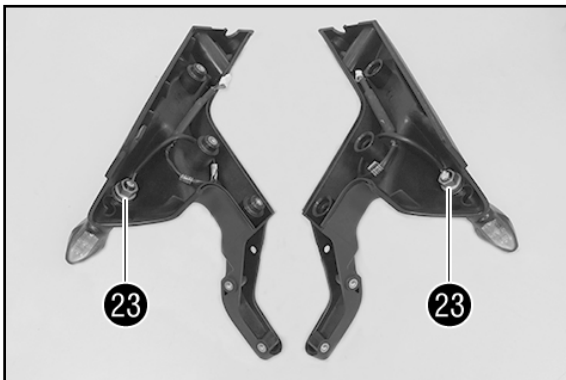

- Retirer les écrous 23 avec les rondelles.
- Retirer le clignotant.

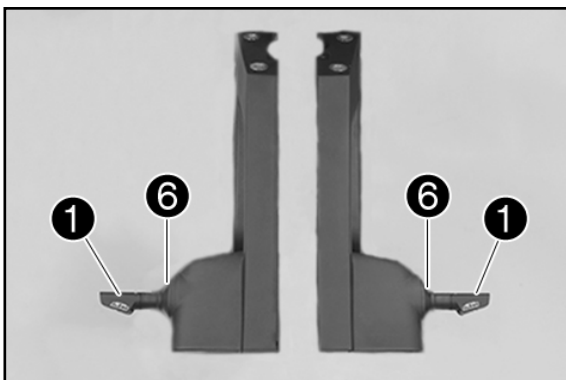

- Prémonter l'adaptateur de clignotant 6 (contenu de la livraison) sur le clignotant 1 (contenu de la livraison).
- Enfiler le clignotant 1 (contenu de la livraison) et le positionner avec l'adaptateur de clignotant 6.

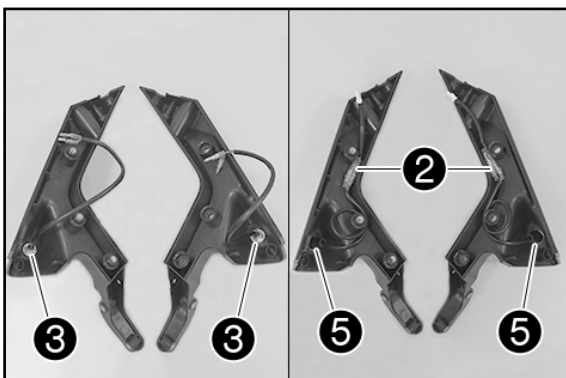

- Mettre en place les écrous 3 avec les rondelles 4 (tous compris dans la livraison) et les serrer.
- Mettre en place les capuchons 5 (contenu de la livraison).
- Brancher les résistances 2 (contenu de la livraison) en respectant les couleurs.
- Positionner le câble.

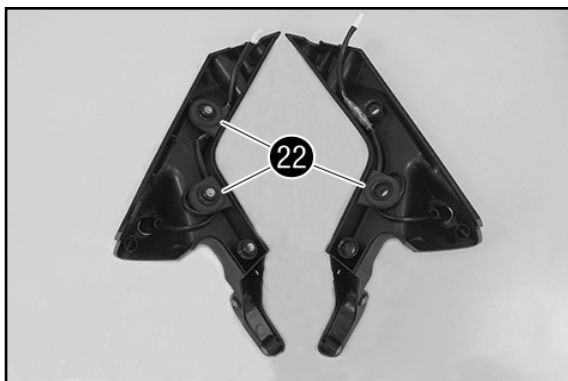

- Monter le support de câble 22 avec la lèvre C vers l'intérieur.

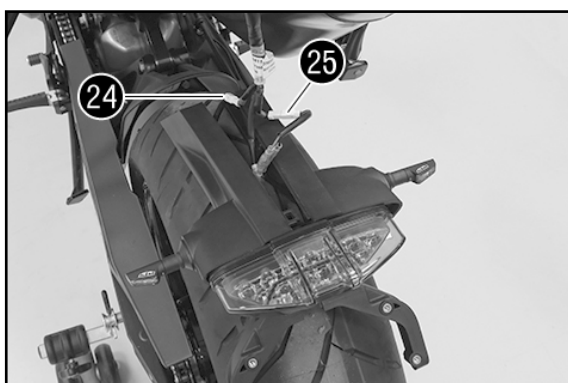
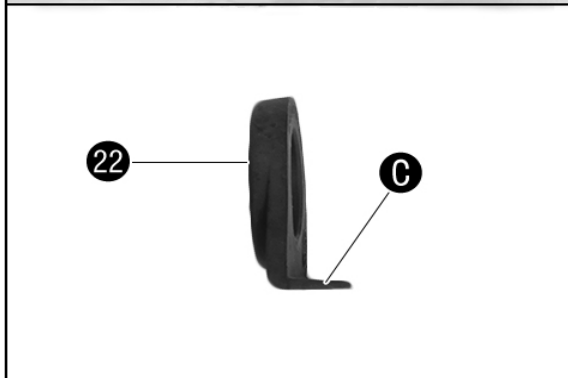

- Brancher les connecteurs 24 et 25 du clignotant.
 - Positionner les demi porte-plaque sur le feu arrière.
 - Poser le câble de manière à ce qu'il ne soit soumis à aucune contrainte.

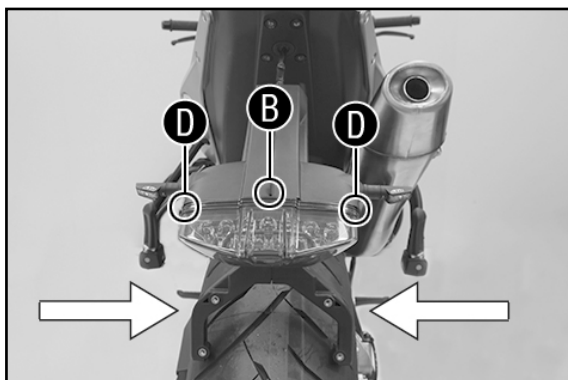

- Enclencher les demi porte-plaque dans la zone B et accrocher le feu arrière dans les zones D.
 - Brancher les demi porte-plaque.

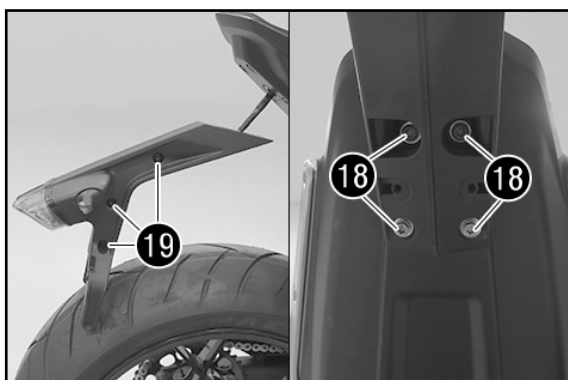

- Mettre en place les vis 19 et les serrer à 5 Nm.
 - Mettre en place la support de plaque d'immatriculation.
 - Mettre en place les vis 18 et les serrer à 10 Nm (Loctite 243).

Travaux ultérieurs

- Contrôler le fonctionnement de l'éclairage.



Clignotants avant 1290 Duke R

Montage

- Couper le contact.
- Dévisser complètement la vis de réglage 7.

REMARQUE

La vis de réglage est maintenue sur la plaque-phare par une fixation à tête de rotule.

Ne pas retirer la vis de réglage de la fixation à tête de rotule.

- Basculer la plaque-phare légèrement vers l'avant et, le cas échéant, débrancher le connecteur 8.

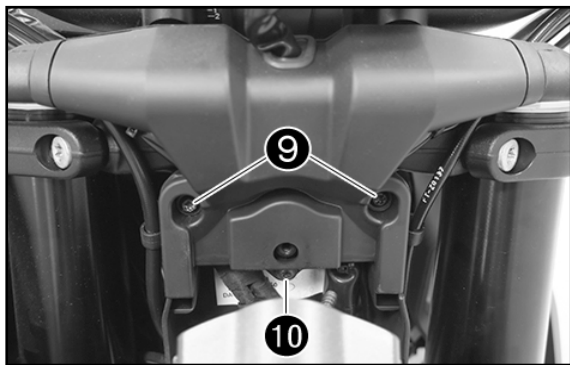

- Retirer les vis 9.
- Retirer la vis 10.

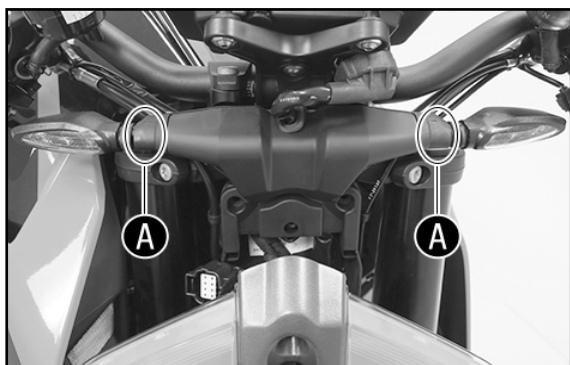

- Saisir les clignotants dans la zone A et appuyer avec précaution dans la direction opposée.

✓ Le cache se desserre.

- Retirer le cache vers le haut.

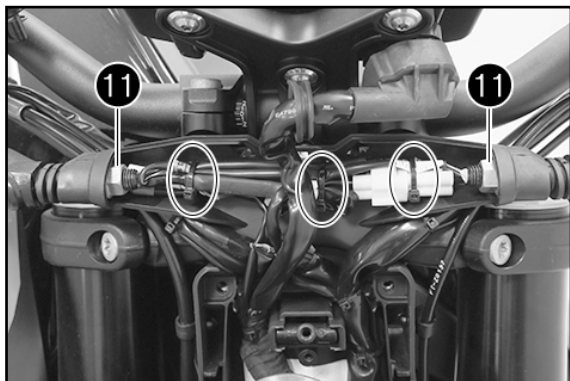

- Desserrer complètement les écrous 11 du filetage.
- Retirer le rilsan.

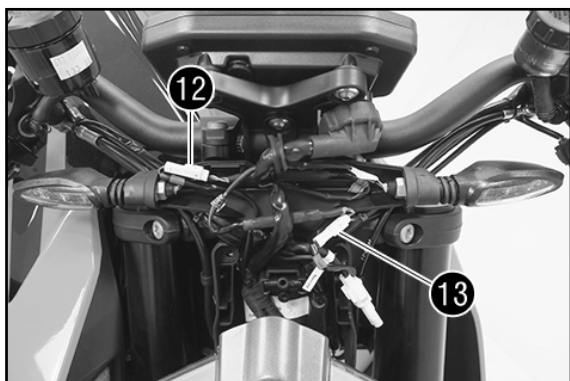

- Débrancher la fiche des clignotants de droite 12 et de gauche 13.
- Dégager les clignotants et les retirer avec les écrous et les rondelles.

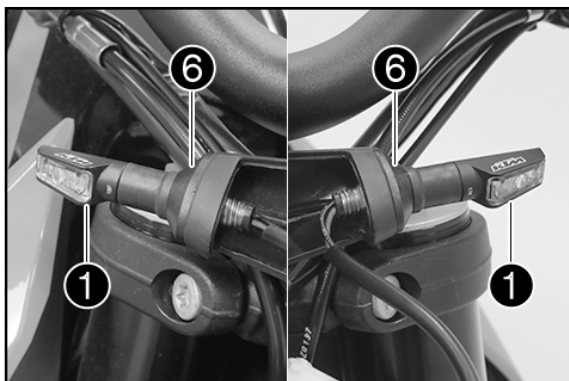

- Prémonter l'adaptateur pour clignotant ⑥ sur les clignotants ① (tous compris dans la livraison).
- Enfiler les clignotants ① (compris dans la livraison) et les positionner avec l'adaptateur ⑥.

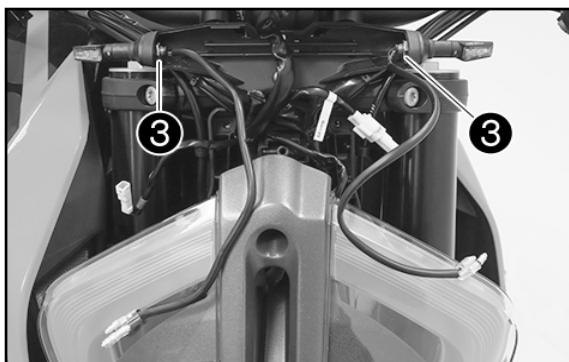

- Mettre en place les écrous ③ avec les rondelles ④ (tous compris dans la livraison) et les serrer.

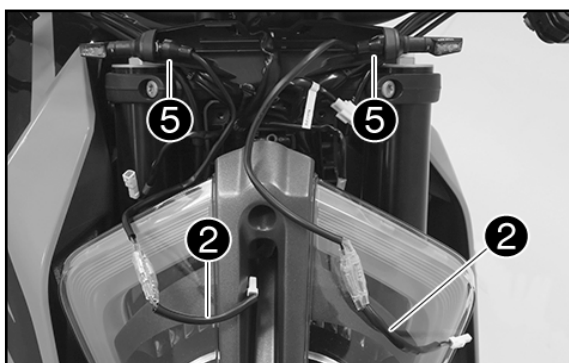

- Mettre en place les capuchons ⑤ (compris dans la livraison).
- Brancher les résistances ② (comprises dans la livraison) en respectant les couleurs.

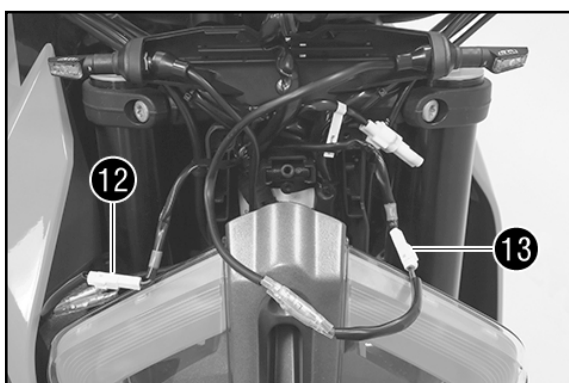

- Brancher la fiche des clignotants de droite ⑫ et de gauche ⑬.

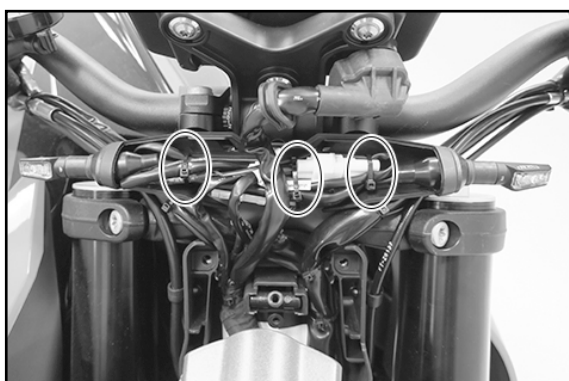

- Poser tous les câbles de manière à ce qu'ils ne soient soumis à aucune contrainte et les bloquer à l'aide d'un rilsan.

! ATTENTION

Veiller à ce que les câbles ne soient ni pliés ni coincés !

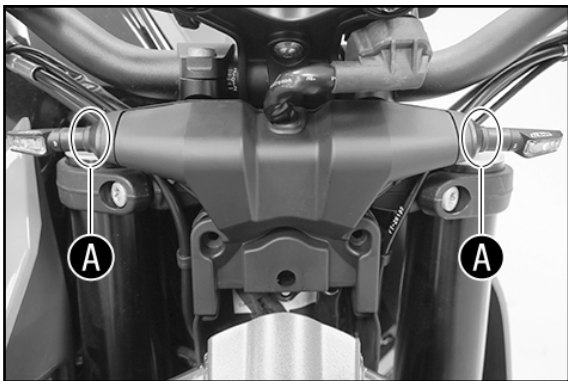

- Positionner le cache et le câble avec la gaine en caoutchouc.
- Saisir les clignotants dans la zone **A** et appuyer avec précaution dans la direction opposée au sens de la marche, tout en appuyant sur le cache.

✓ Le cache s'enclenche avec un son perceptible.

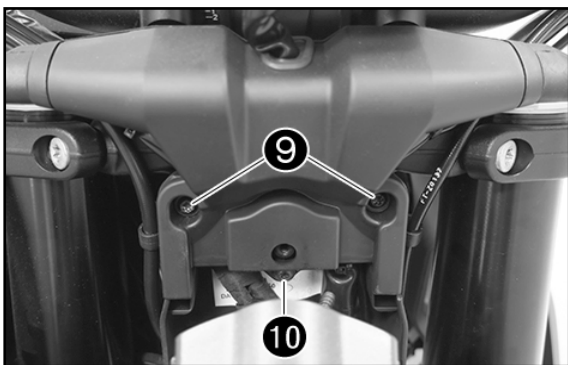

- Mettre en place les vis **9** et les serrer à 5 Nm.
- Mettre la vis **10** en place et la serrer à 5 Nm.

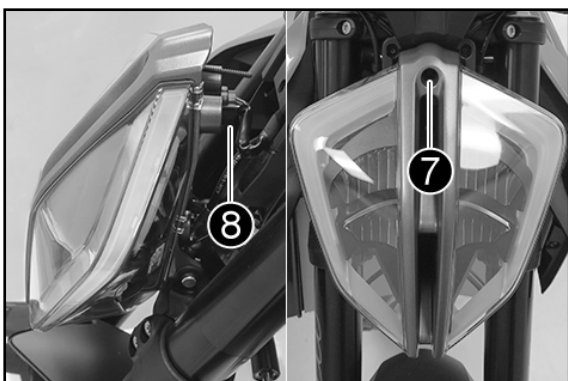

- Si nécessaire, brancher la fiche **8**.
- Positionner la plaque-phare.
- Mettre en place la vis de réglage **7**.

Travaux ultérieurs

- Contrôler le réglage du phare (voir le manuel d'utilisation).
- Régler la portée du phare (voir le manuel d'utilisation).
- Contrôler le fonctionnement de l'éclairage.

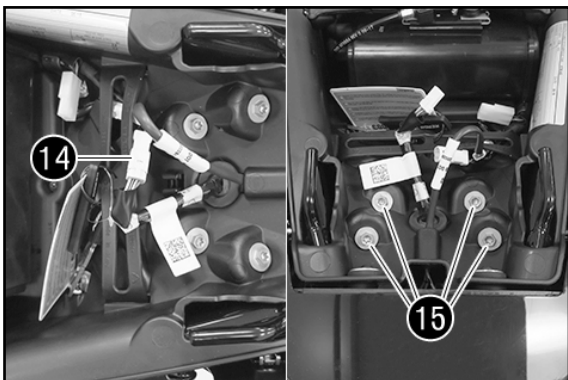

Clignotants arrière 1290 Super Duke R

Travaux préliminaires

- Déposer la selle passager (voir manuel d'utilisation).

Montage

- Débrancher la fiche **14**.
- Retirer les vis **15**.
- Retirer le support de plaque d'immatriculation.

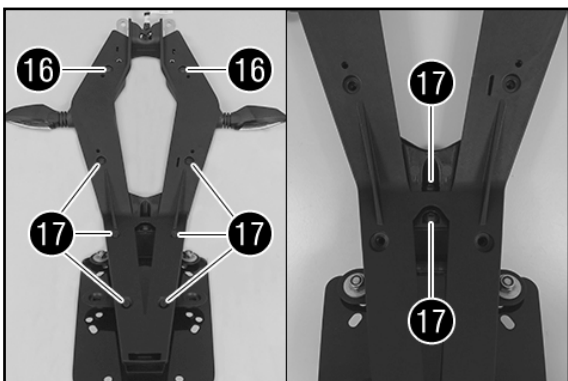

- Retirer les vis **16**.
- Retirer les vis **17**.



- Enlever le cache.
- Dégager le câble de l'éclairage de plaque d'immatriculation et débrancher la fiche 18.
- Retirer le cache et l'éclairage de plaque d'immatriculation.

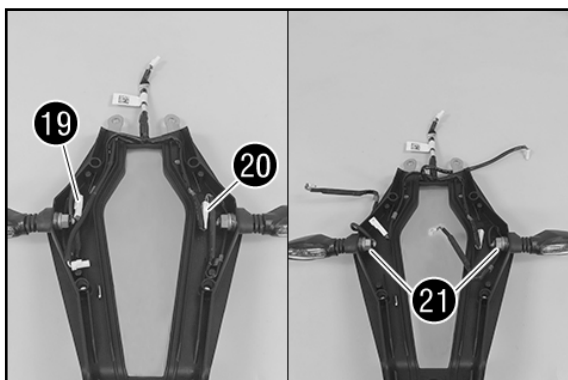

- Dégager tous les câbles.
- Débrancher les fiches de clignotants de gauche 19 et de droite 20.
- Desserrer complètement les écrous 21 du filetage.
- Dégager les clignotants et les retirer avec les écrous et les rondelles.

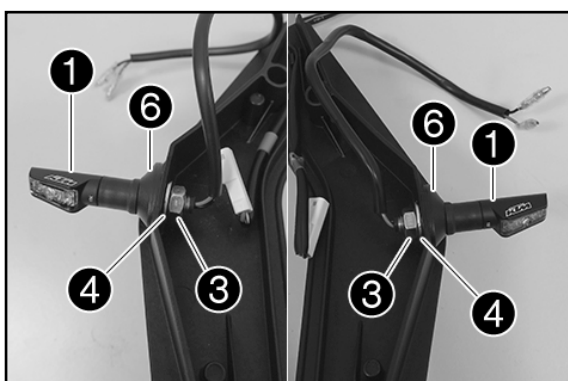

- Prémontier l'adaptateur pour clignotant 6 sur les clignotants 1 (tous compris dans la livraison).
- Percer les trous de fixation de l'adaptateur 6 avec un outil approprié.
- Enfiler les clignotants 1 et les positionner avec l'adaptateur 6.
- Mettre en place les écrous 3 avec les rondelles 4 (tous compris dans la livraison) et les serrer.

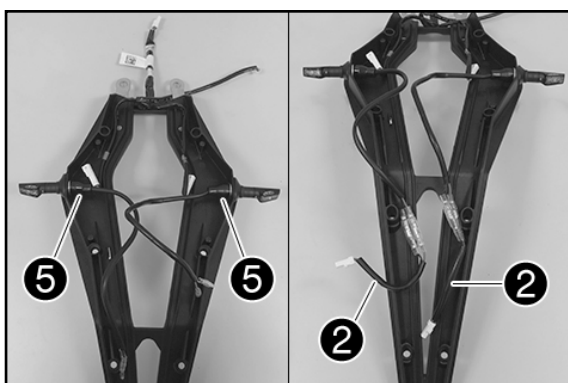

- Mettre en place les capuchons 5 (compris dans la livraison).
- Brancher les résistances 2 (comprises dans la livraison) en respectant les couleurs.

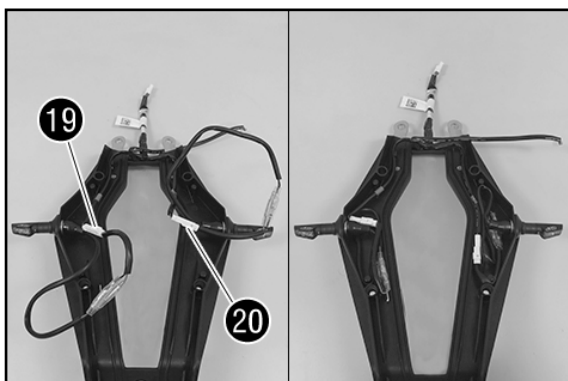

- Brancher les fiches de clignotants de gauche 19 et de droite 20.
- Poser tous les câbles de manière à ce qu'ils ne soient soumis à aucune contrainte.

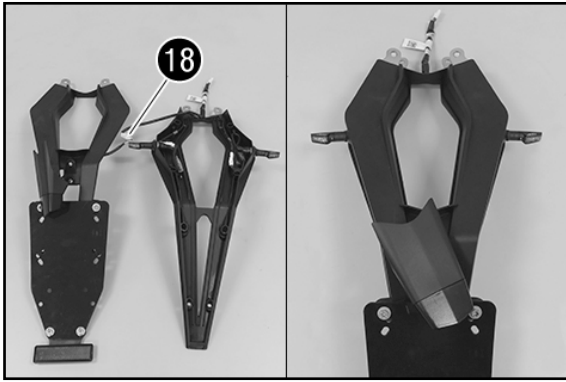

- Brancher la fiche de l'éclairage de plaque d'immatriculation 18.
- Positionner le cache.
- Poser le câble de l'éclairage de plaque d'immatriculation hors tension.

! ATTENTION

Veiller à ce que les câbles ne soient ni pliés ni coincés !

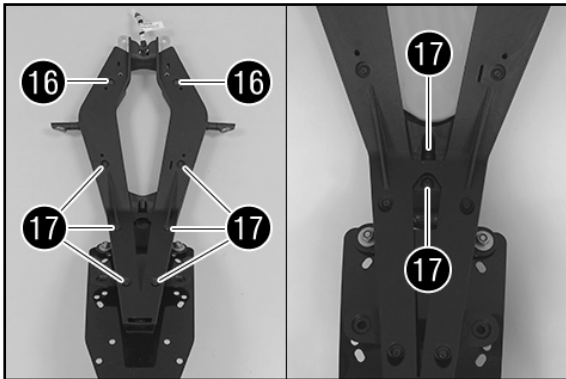

- Monter les vis 16 sans les serrer.
- Mettre les vis 17 en place sans les serrer.
- Positionner l'éclairage de plaque d'immatriculation, puis mettre en place et serrer les vis 17.
- Serrer toutes les vis 16 et 17.

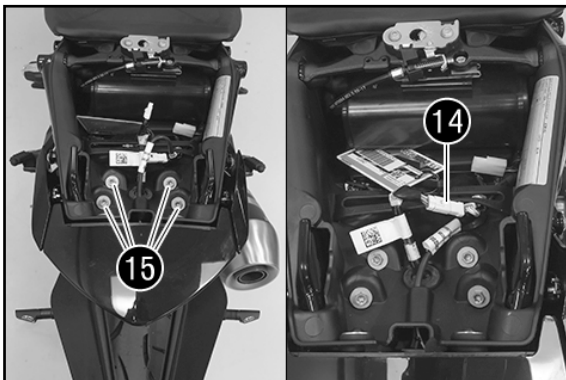

- Placer le support de plaque d'immatriculation et faire passer le câble par le haut.
- Mettre en place les vis 15 et les serrer à 10 Nm (Loctite 243).
- Brancher le connecteur 14.

Travaux ultérieurs

- Mettre en place la selle passager (voir manuel d'utilisation).
- Contrôler le fonctionnement de l'éclairage.



Clignotants arrière 1290 Super Duke GT

Travaux préliminaires

- Déposer la selle passager (voir manuel d'utilisation).

Montage

- Débrancher le connecteur 7.



- Retirer les vis 8.
- Retirer le support de plaque d'immatriculation.

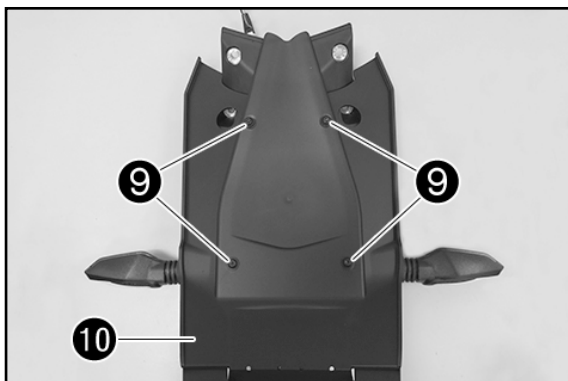

- Retirer les vis 9.
- Retirer le cache 10.

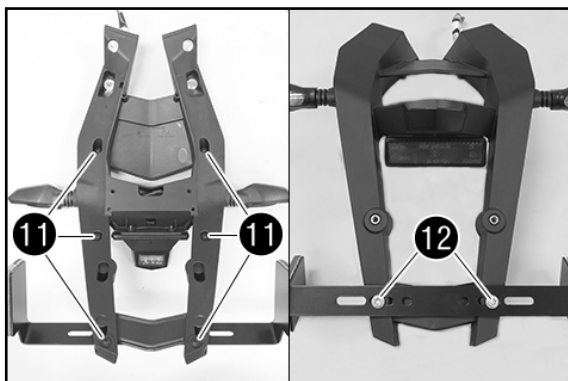

- Retirer les vis 11.

Modèles américains :

- Retirer les vis 12.
- Retirer les réflecteurs.

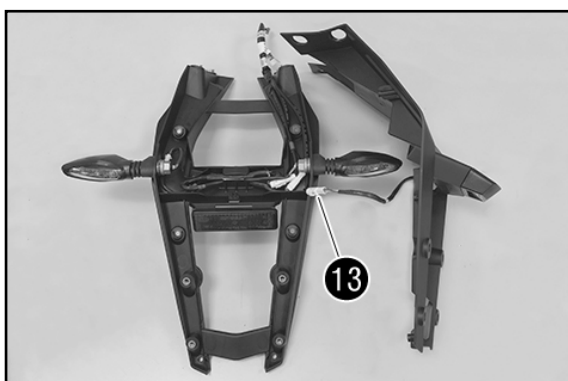

- Enlever le cache.
- Dégager le câble de l'éclairage de plaque d'immatriculation et débrancher la fiche 13.
- Retirer le cache et l'éclairage de plaque d'immatriculation.

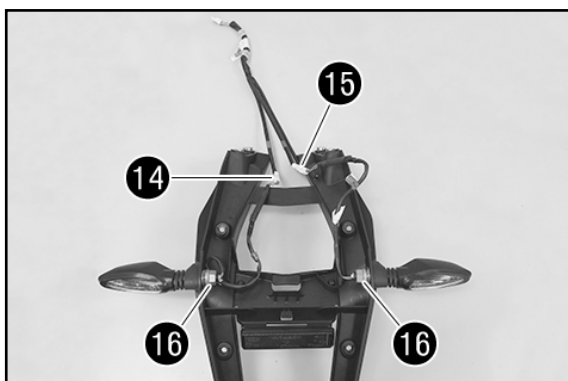

- Dégager tous les câbles.
- Débrancher les fiches des clignotants de gauche 14 et de droite 15.
- Desserrer complètement les écrous 16 du filetage.
- Dégager les clignotants et les retirer avec les écrous et les rondelles.

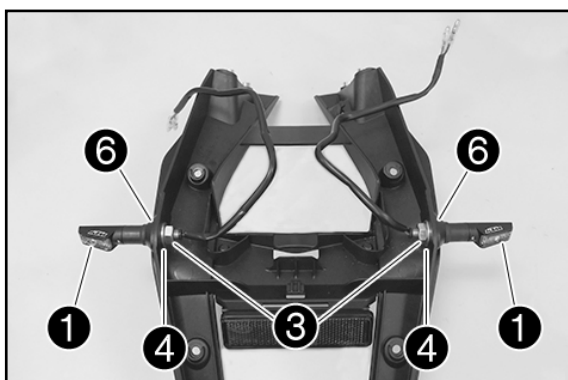

- Prémonter l'adaptateur pour clignotant 6 sur les clignotants 1 (tous compris dans la livraison).
- Enfiler les clignotants 1 et les positionner avec l'adaptateur 6.
- Mettre en place les écrous 3 avec les rondelles 4 (tous compris dans la livraison) et les serrer.

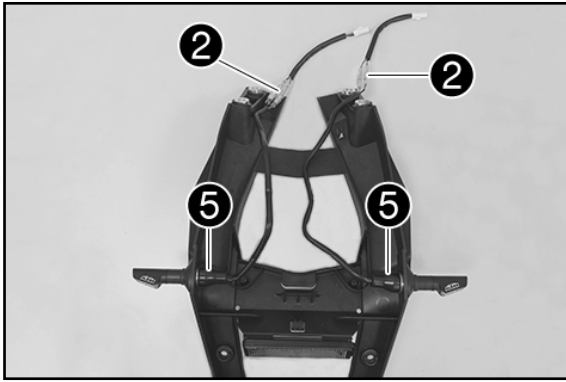

- Mettre en place les capuchons ⑤ (compris dans la livraison).
- Brancher les résistances ② (comprises dans la livraison) en respectant les couleurs.

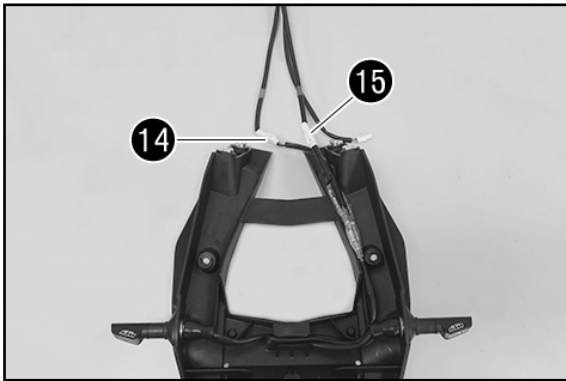

- Poser tous les câbles de manière à ce qu'ils ne soient soumis à aucune contrainte.
- Brancher les fiches des clignotants de gauche ⑭ et de droite ⑮.

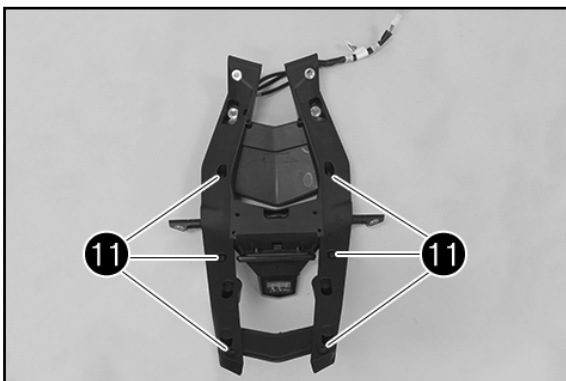

- Brancher la fiche de l'éclairage de plaque d'immatriculation ⑬.
- Poser le câble de l'éclairage de plaque d'immatriculation hors tension.
- Positionner le cache.

! ATTENTION

Veiller à ce que les câbles ne soient ni pliés ni coincés !

- Mettre les vis ⑪ en place et les serrer.

Modèles américains :

- Positionner les réflecteurs.
- Mettre en place les vis ⑫ et les serrer.

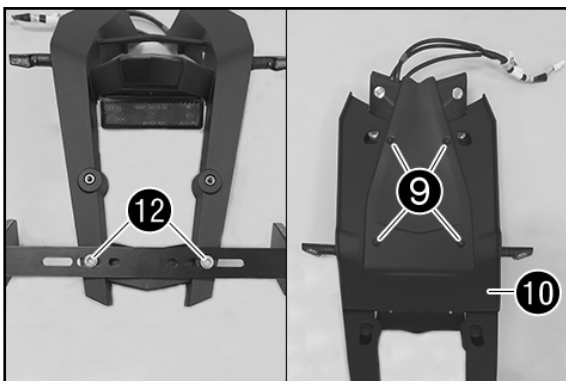

- Mettre le cache ⑩ en place.
- Mettre les vis ⑨ en place et les serrer.

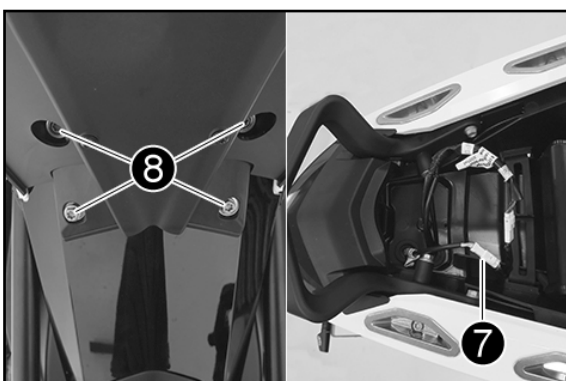

- Placer le support de plaque d'immatriculation et faire passer le câble par le haut.
- Mettre les vis ⑧ en place et les serrer à 10 Nm (Loctite 243).
- Brancher le connecteur ⑦.

Travaux ultérieurs

- Mettre en place la selle passager (voir manuel d'utilisation).
- Contrôler le fonctionnement de l'éclairage.

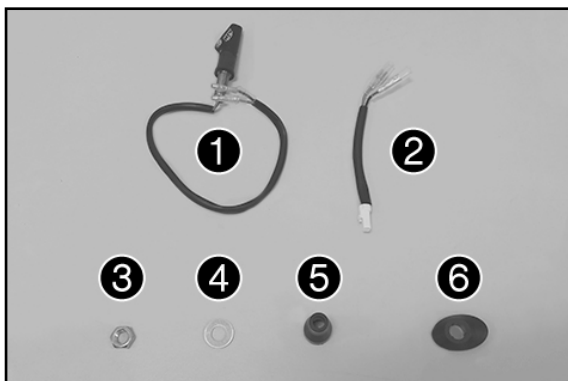

Volumen de suministro

- 1x intermitente ❶
- 1x resistencia ❷
- 1x tuerca ❸
- 1x arandela ❹
- 1x cubierta de protección ❺
- 1x adaptador de intermitente ❻

Intermitente delantero 790 Duke

Montaje

- Desconectar el sistema de encendido.
- Retirar los tornillos ❷.

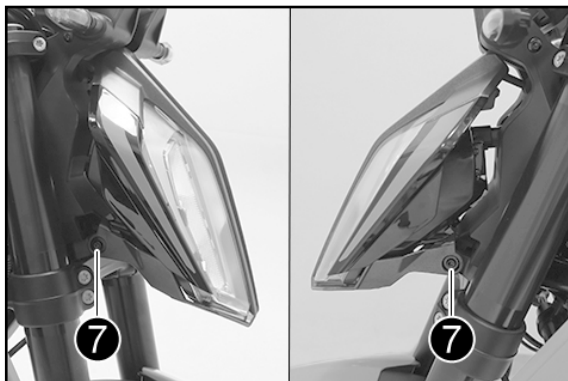

- Extraer completamente el mando de ajuste ❸.

AVISO

El mando de ajuste está sujeto mediante un soporte de rótula a la máscara de faro.
No sacar el mando de ajuste del soporte de rótula.

- Abatir la máscara de faro ligeramente hacia delante y desconectar la clema ❹.
- Quitar el faro.

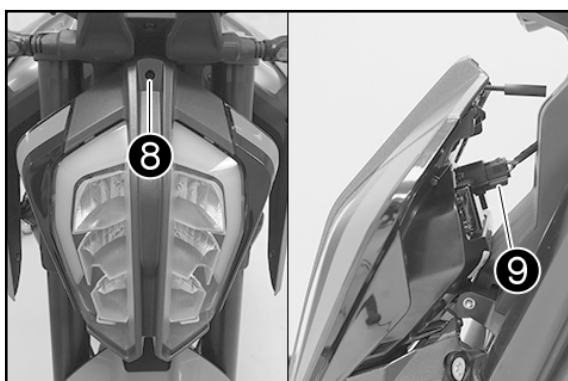

- Retirar los tornillos ❿.
- Retirar los tornillos ⓫.
- Retirar los tornillos ⓬.

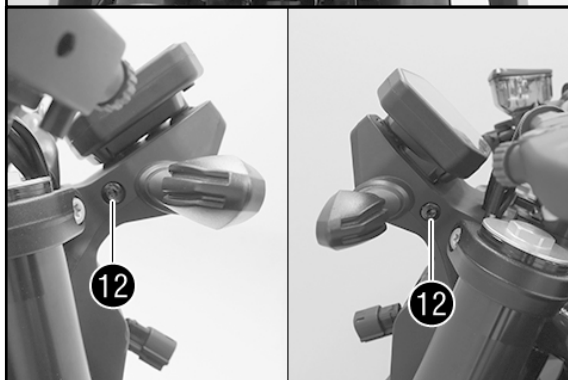
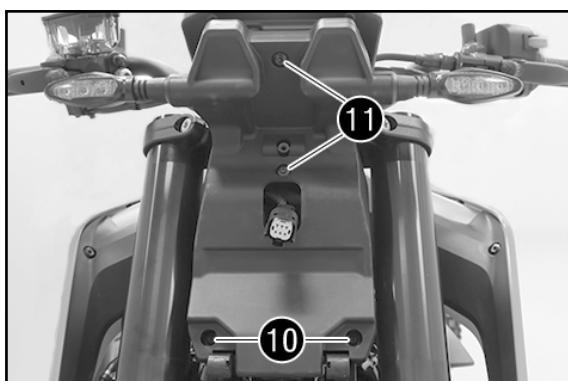

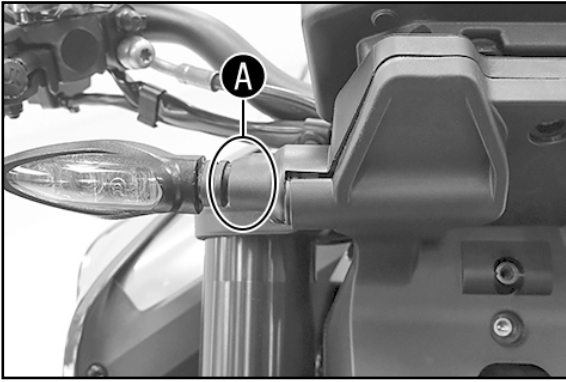

- Sujetar el intermitente en la zona **A** y empujarlo con cuidado en contra de la dirección de marcha.

✓ La tapa se suelta como se muestra en la imagen.

- Repetir el paso de trabajo en el lado opuesto.
- Retirar la tapa.

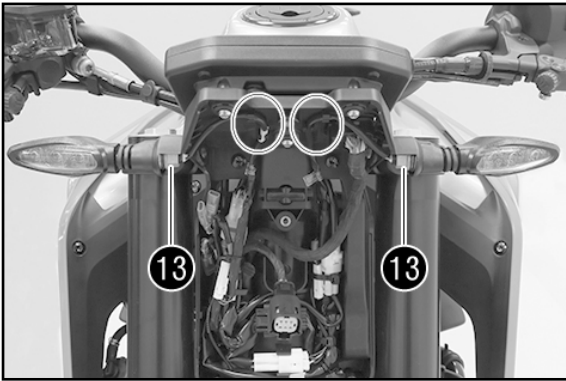

- Soltar completamente las tuercas **13** de la rosca.
- Retirar el cable del intermitente de las fijaciones de arriba.

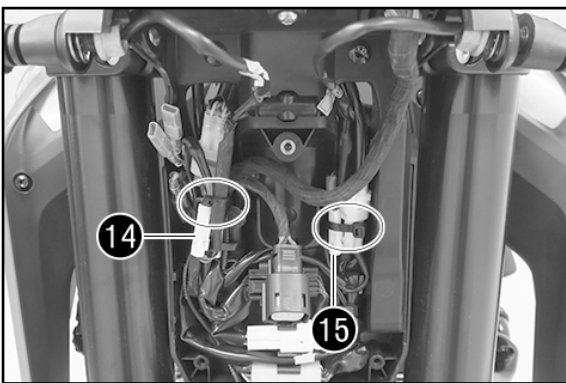

- Retirar las bridas.
- Desconectar los conectores del intermitente a la derecha **14** e izquierda **15**.
- Retirar el intermitente con las tuercas y arandelas.

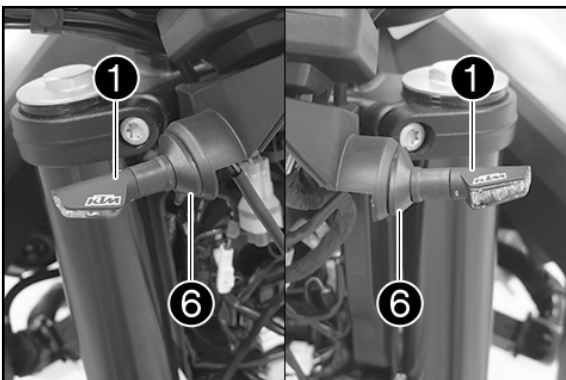

- Premontar el adaptador del intermitente **6** (volumen de suministro) en el intermitente **1** (volumen de suministro).
- Insertar el intermitente **1** (volumen de suministro) y colocarlo con el adaptador del intermitente **6**.

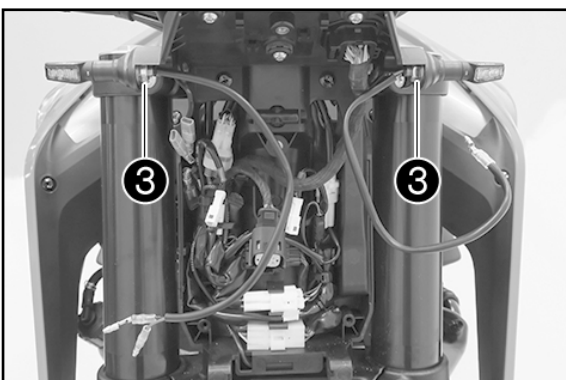

- Montar y apretar las tuercas **3** con las arandelas **4** (todo incluido en el volumen de suministro).

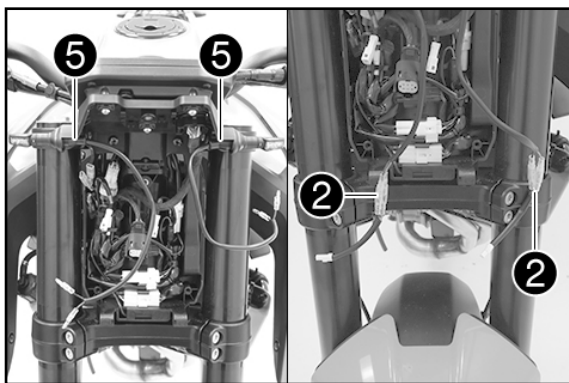

- Montar las cubiertas de protección ⑤ (volumen de suministro).
- Insertar las resistencias ② (volumen de suministro) según sus colores.

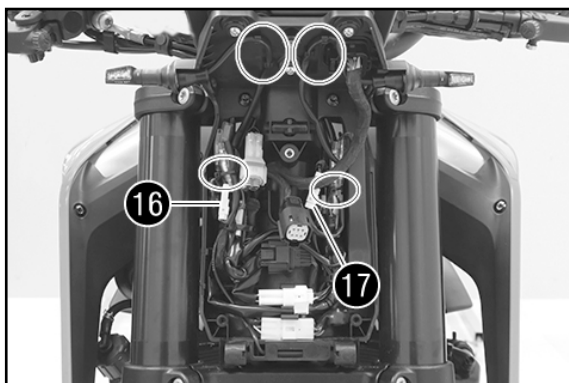

- Enchufar los conectores del intermitente ⑯ y ⑰.
- Montar el cable del intermitente en las fijaciones de arriba.
- Tender todos los cables sin tensiones y asegurarlos con bridas.

! AVISO

¡Asegurarse de que el cable no pueda retorcerse ni quedar apriionado!

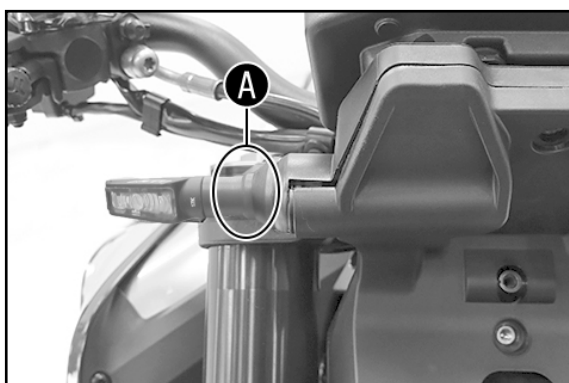

- Colocar la tapa pasando el conector del faro por la abertura.
- Sujetar el intermitente en la zona A y empujarlo con cuidado en contra de la dirección de marcha, a la vez que se aprieta la tapa.

✓ La tapa se enclava de manera audible.

- Repetir el paso de trabajo en el lado opuesto.

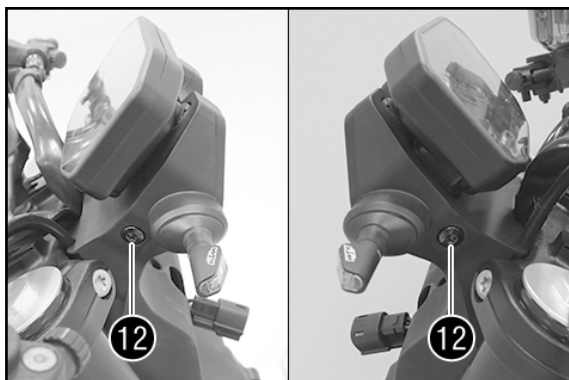

- Montar los tornillos ⑫ y apretarlos a 5 Nm.
- Montar los tornillos ⑪ y apretarlos a 5 Nm.
- Montar los tornillos ⑩ y apretarlos a 2 Nm.

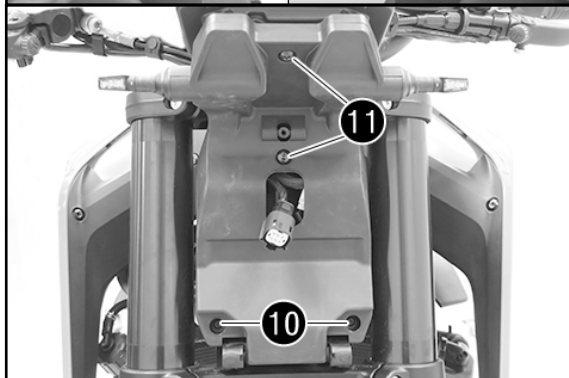

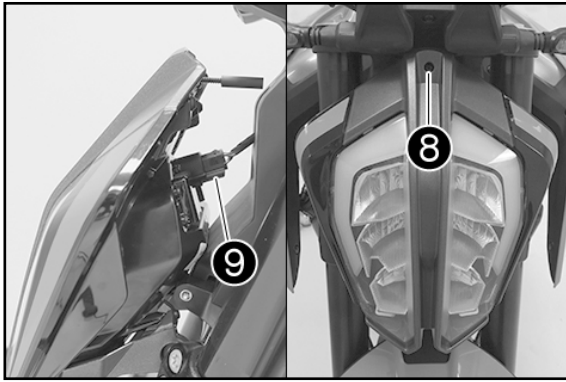

- Enchufar la clema 9.
- Colocar la máscara de faro.
- Montar el mando de ajuste 8.

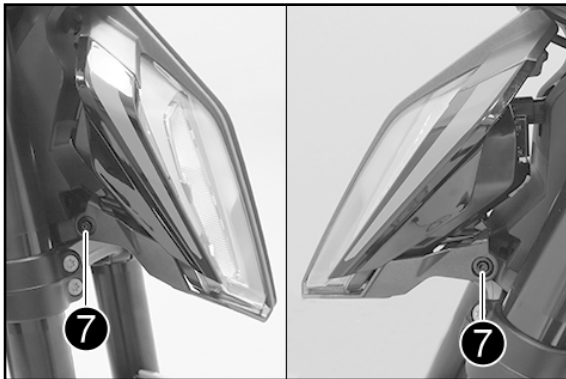

- Montar los tornillos 7 y apretarlos a 2 Nm.

Trabajos posteriores

- Comprobar el ajuste del faro (véase el manual de instrucciones).
- Ajustar la distancia de alumbrado del faro (véase el manual de instrucciones).
- Comprobar el funcionamiento del alumbrado.

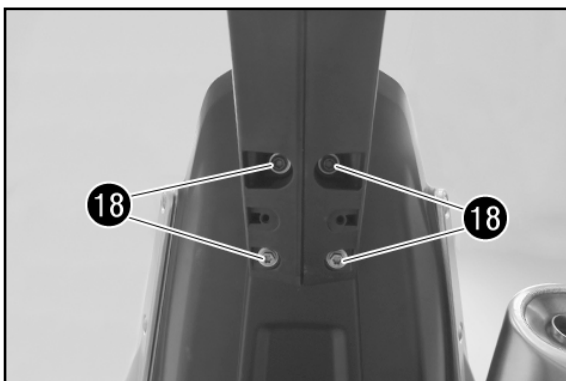

Intermitentes traseros 790 Duke

Montaje

- Retirar los tornillos 18.
- Depositar el soporte de matrícula en la rueda trasera.

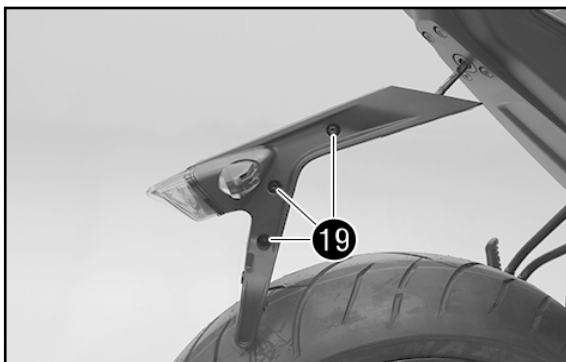

- Retirar los tornillos 19.
- Girar hacia fuera las mitades del soporte de la placa de matrícula y desengancharlas por la zona B.
- Depositar el piloto trasero en la rueda trasera.

AVISO

Si es necesario, se puede retirar el soporte de matrícula completo. Para ello, desconectar la clema correspondiente del asiento del pasajero y extraer el cable con el pasahilos de caucho.

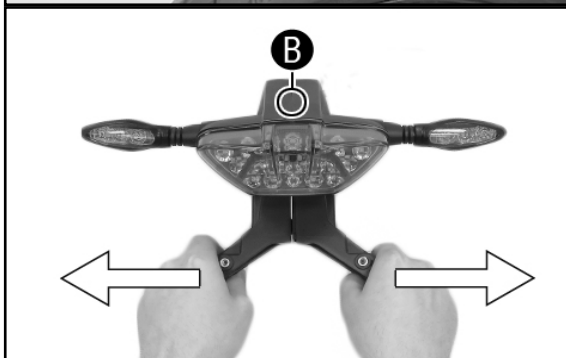

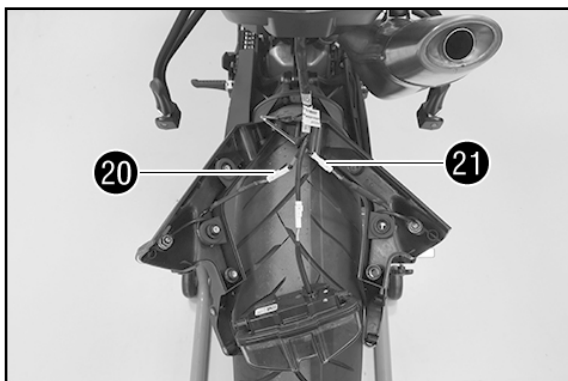

- Desconectar los conectores del intermitente 20 y 21.
- Quitar las mitades del soporte de matrícula.

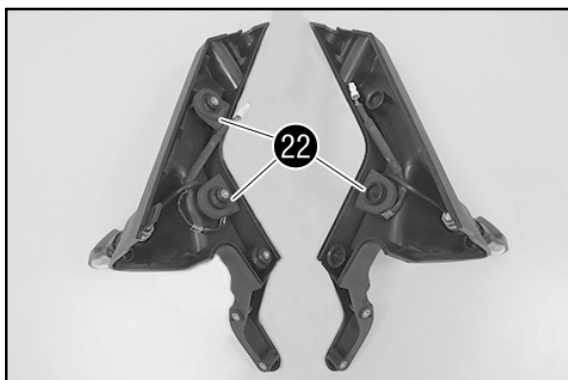

- Retirar los portacables 22.

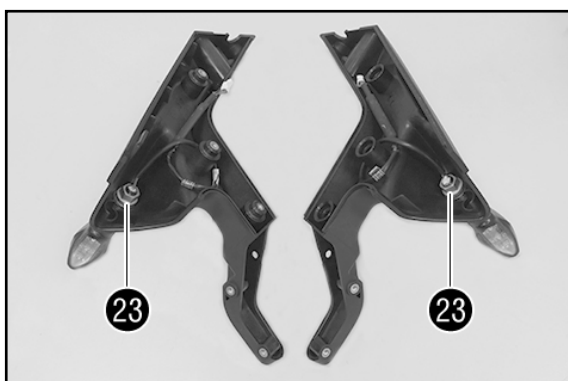

- Retirar las tuercas 23 con las arandelas.
- Retirar el intermitente.

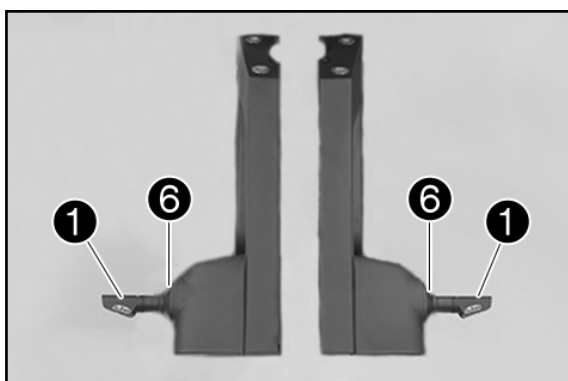

- Premontar el adaptador del intermitente 6 (volumen de suministro) en el intermitente 1 (volumen de suministro).
- Insertar el intermitente 1 (volumen de suministro) y colocarlo con el adaptador del intermitente 6.

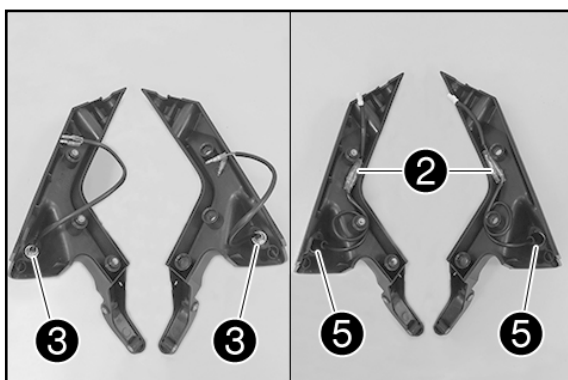

- Montar y apretar las tuercas 3 con las arandelas 4 (todo incluido en el volumen de suministro).
- Montar las cubiertas de protección 5 (volumen de suministro).
- Insertar las resistencias 2 (volumen de suministro) según sus colores.
- Posicionar el cable.

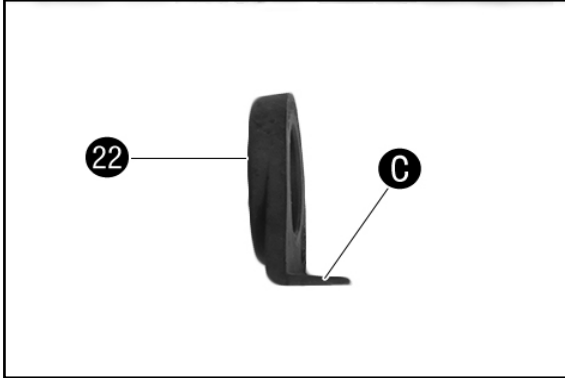
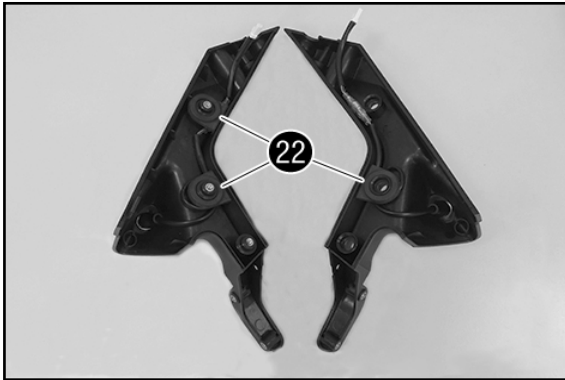

- Montar los portacables 22 con el labio C hacia dentro.

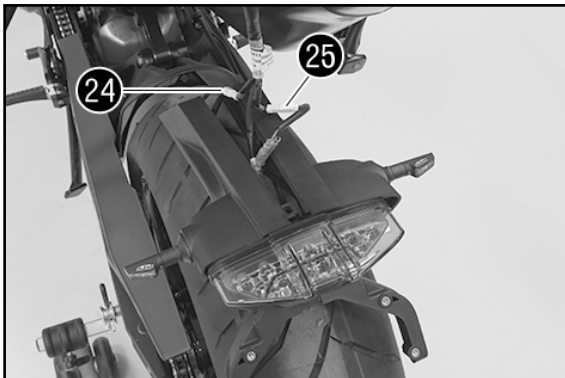

- Enchufar los conectores del intermitente 24 y 25.
 - Posicionar las mitades del soporte de matrícula en el piloto trasero.
 - Tender los cables sin tensiones.

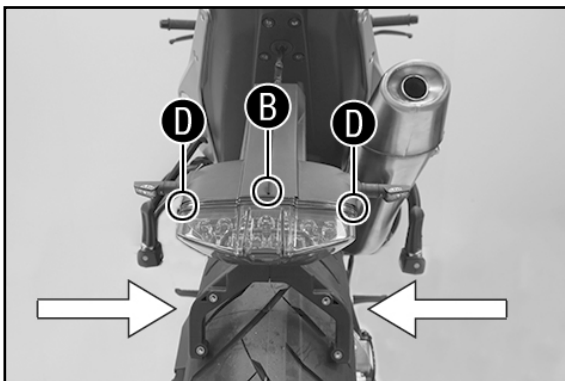

- Encajar las mitades del soporte de la placa de matrícula en la zona B y enganchar el piloto trasero en las zonas D.
 - Ensamblar las mitades del soporte de matrícula.

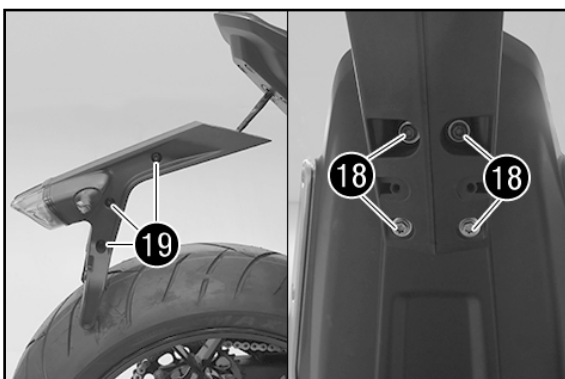

- Montar los tornillos 19 y apretarlos a 5 Nm.
 - Posicionar el soporte de la placa de matrícula.
 - Montar los tornillos 18 y apretarlos a 10 Nm (Loctite 243).

Trabajos posteriores

- Comprobar el funcionamiento del alumbrado.

Intermitente delantero 1290 Duke R

Montaje

- Desconectar el sistema de encendido.
- Desenroscar completamente el tornillo de ajuste 7.

AVISO

El tornillo de ajuste está sujeto mediante un soporte de rótula a la máscara de faro.

No sacar el tornillo de ajuste del soporte de rótula.

- Abatir la máscara de faro ligeramente hacia delante y, en caso necesario, desenchufar la clema 8.

- Retirar los tornillos 9.
- Retirar el tornillo 10.

- Sujetar el intermitente en la zona A y empujarlo con cuidado en contra de la dirección de marcha.

✓ La tapa se suelta.

- Retirar la tapa hacia arriba.

- Soltar completamente las tuercas 11 de la rosca.
- Retirar las bridas.

- Desenchufar la clema del intermitente derecho 12 e izquierdo 13.
- Extraer el intermitente y retirarlo con tuercas y arandelas.

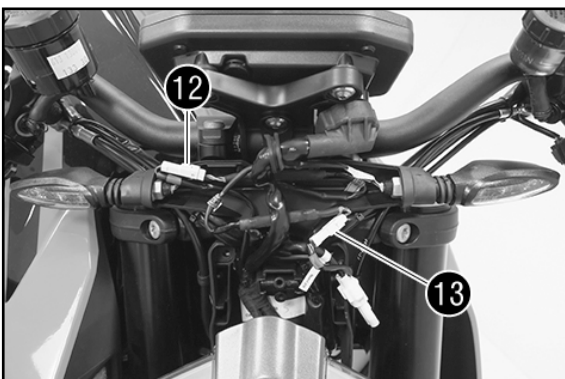
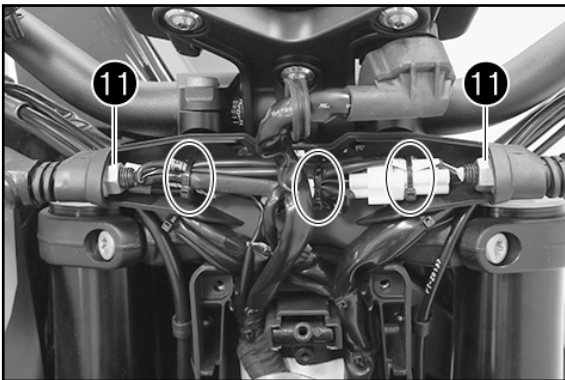
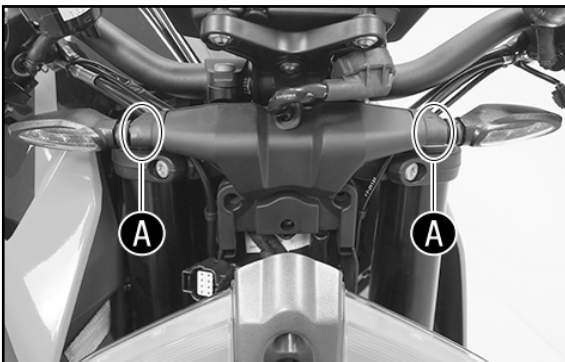
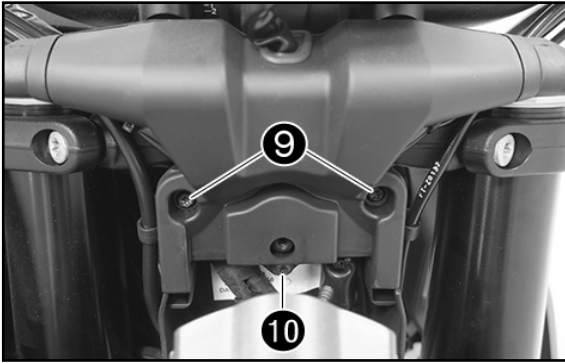

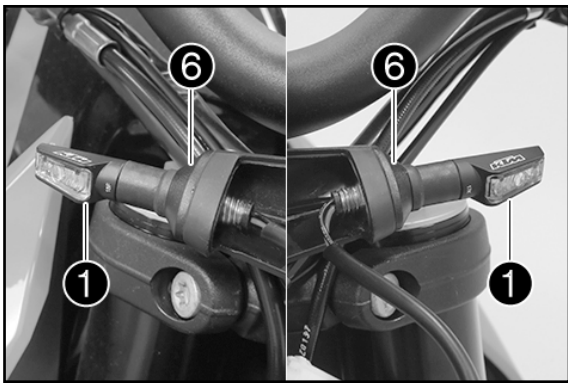

- Premontar el adaptador del intermitente ⑥ (volumen de suministro) en el intermitente ① (volumen de suministro).
- Insertar el intermitente ① (volumen de suministro) y colocarlo con el adaptador del intermitente ⑥.

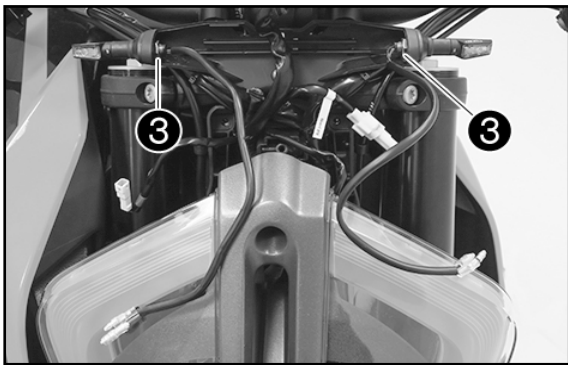

- Montar y apretar las tuercas ③ con las arandelas ④ (todo incluido en el volumen de suministro).

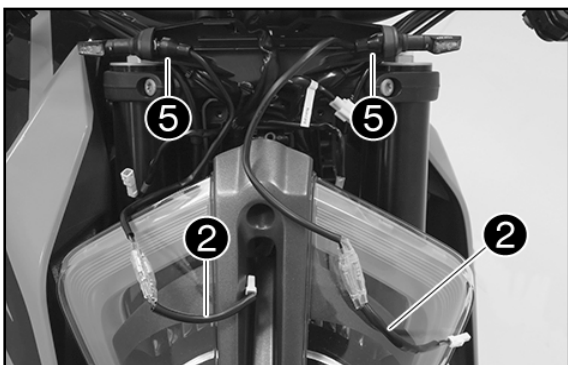

- Montar las cubiertas de protección ⑤ (volumen de suministro).
- Insertar las resistencias ② (volumen de suministro) según sus colores.

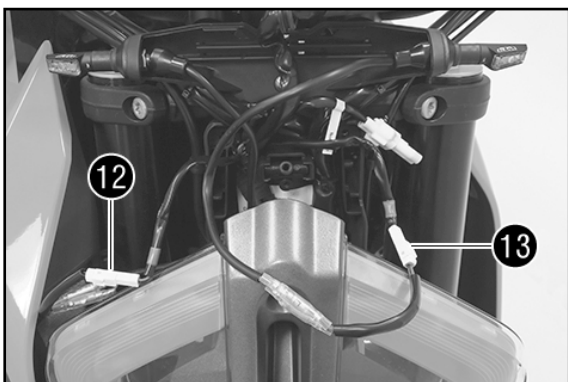

- Enchufar la clema del intermitente derecho ⑫ e izquierdo ⑬.

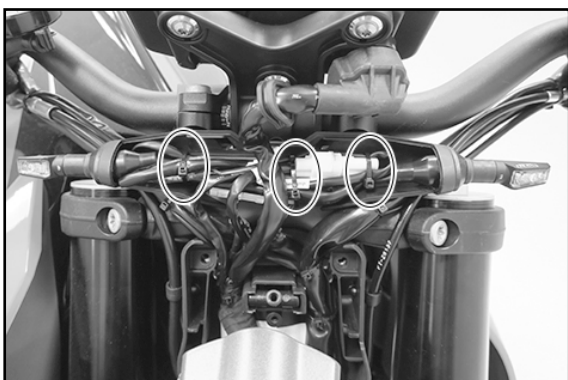

- Tender todos los cables sin tensiones y asegurarlos con bridas.

! AVISO
¡Asegurarse de que el cable no pueda retorcerse ni quedar aprisionado!



- Colocar la tapa y el cable con el pasahilos de caucho.
 - Sujetar el intermitente en la zona **A** y empujarlo con cuidado en contra de la dirección de marcha al tiempo que se presiona la tapa.
- ✓ La tapa se enclava con un chasquido audible.

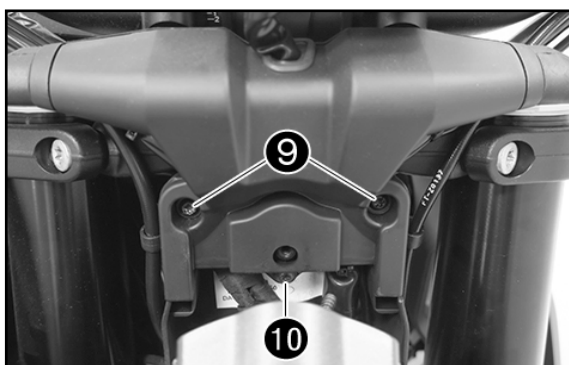

- Montar los tornillos **9** y apretarlos a 5 Nm.
- Montar el tornillo **10** y apretarlo a 5 Nm.

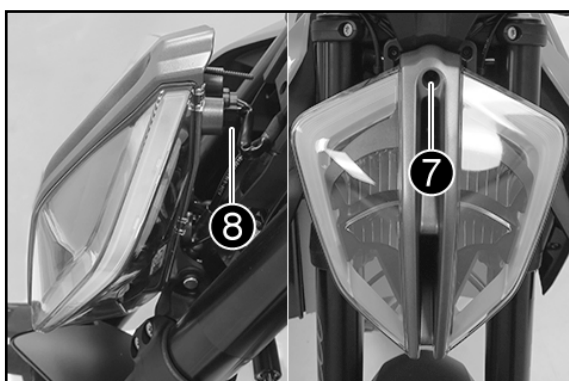

- En caso necesario, enchufar la clema **8**.
- Colocar la máscara de faro.
- Montar el tornillo de ajuste **7**.

Trabajos posteriores

- Comprobar el ajuste del faro (véase el manual de instrucciones).
- Ajustar la distancia de alumbrado del faro (véase el manual de instrucciones).
- Comprobar el funcionamiento del alumbrado.

Intermitente trasero 1290 Super Duke R

Trabajos previos

- Quitar el asiento del pasajero (véase el manual de instrucciones).

Montaje

- Desenchufar la clema **14**.
- Retirar los tornillos **15**.
- Retirar el soporte de matrícula.

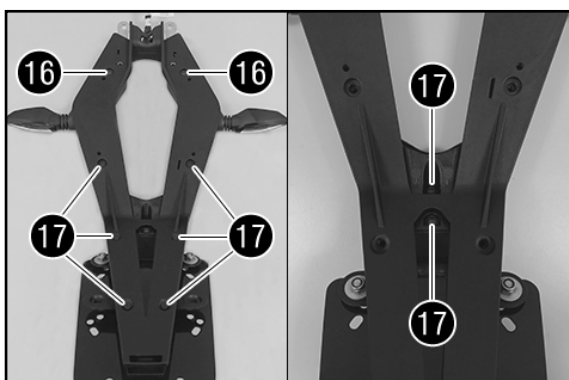
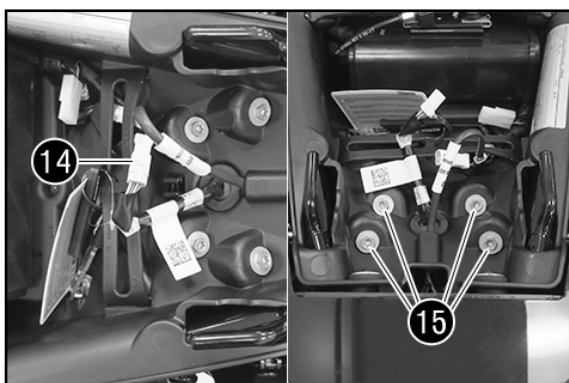

- Retirar los tornillos **16**.
- Retirar los tornillos **17**.

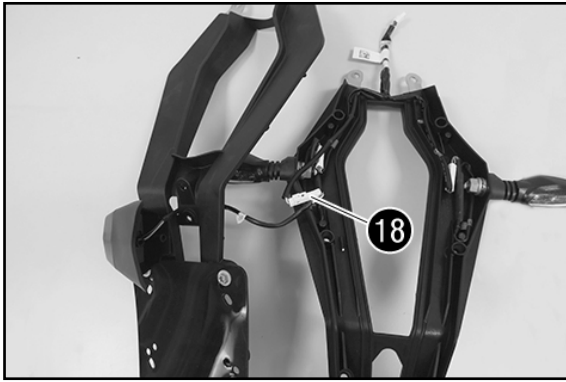

- Quitar la tapa.
- Extraer el cable de la luz de la matrícula y desenchufar la clema 18.
- Retirar la tapa con la luz de la matrícula.

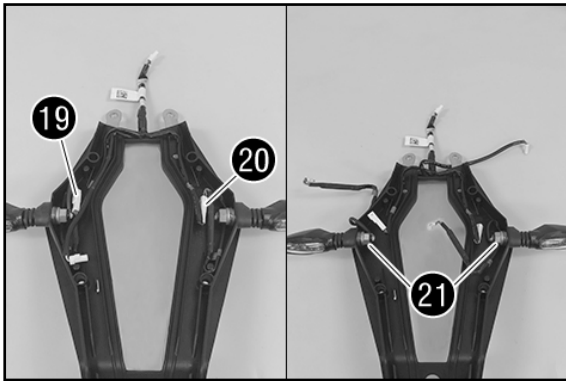

- Dejar todos los cables al descubierto.
- Desenchufar la clema del intermitente izquierdo 19 y derecho 20.

- Soltar completamente las tuercas 21 de la rosca.
- Extraer el intermitente y retirarlo con tuercas y arandelas.

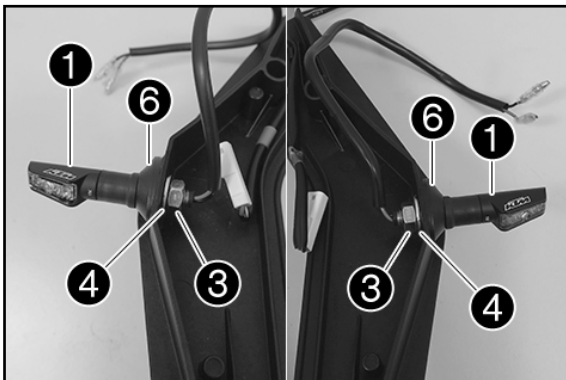

- Premontar el adaptador del intermitente 6 en el intermitente 1 (todo incluido en el volumen de suministro).
- Taladrar los orificios de montaje para el adaptador de intermitente 6 con una herramienta adecuada.
- Insertar el intermitente 1 y colocarlo con el adaptador del intermitente 6.
- Montar y apretar las tuercas 3 con las arandelas 4 (todo incluido en el volumen de suministro).

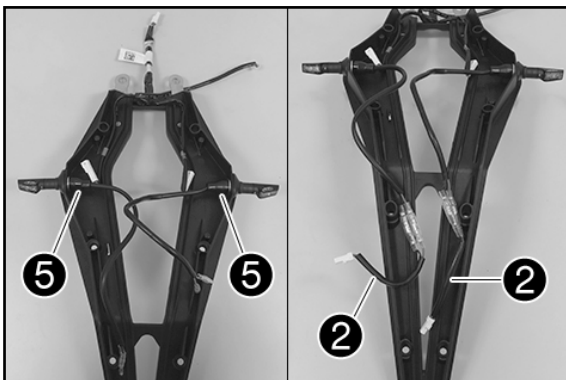

- Montar las cubiertas de protección 5 (volumen de suministro).
- Insertar las resistencias 2 (volumen de suministro) según sus colores.

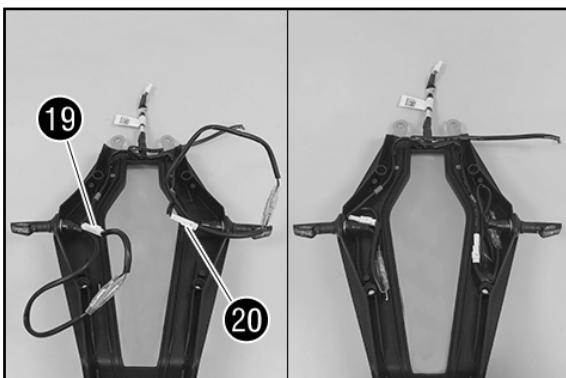

- Enchufar la clema del intermitente izquierdo 19 y derecho 20.
- Tender todos los cables sin tensiones.

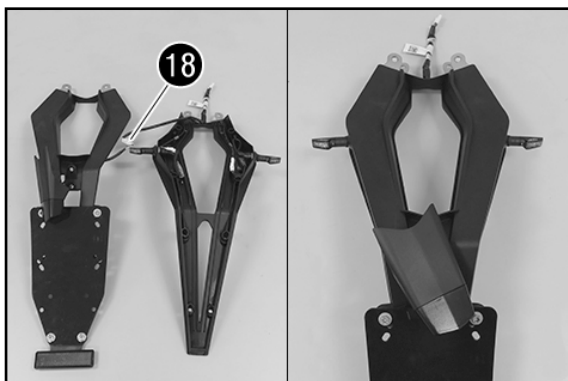

- Enchufar la clema de la luz de la matrícula 18.
- Colocar la tapa.
- Tender el cable de la luz de la matrícula sin tensiones.

! AVISO

¡Asegurarse de que los cables no puedan retorcerse ni quedar aprisionados!

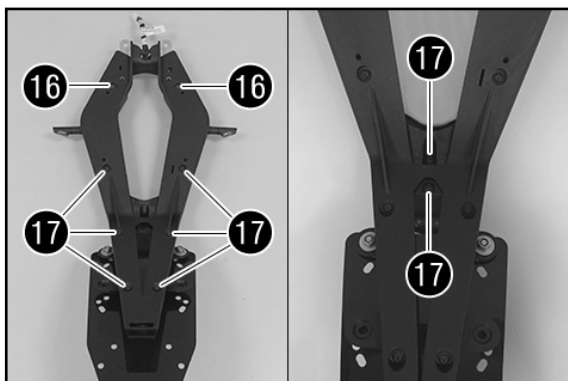

- Montar los tornillos 16, pero no apretarlos todavía.
- Montar los tornillos 17, pero no apretarlos todavía.
- Colocar la luz de la matrícula y montar y apretar los tornillos 17.
- Apretar todos los tornillos 16 y 17.

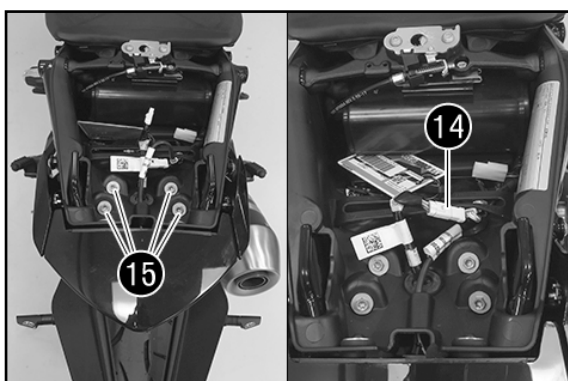

- Colocar el soporte de matrícula y pasar el cable por la parte superior.
- Montar los tornillos 15 y apretarlos a 10 Nm (Loctite 243).
- Enchufar la clema 14.

Trabajos posteriores

- Montar el asiento del pasajero (véase el manual de instrucciones).
- Comprobar el funcionamiento del alumbrado.

Intermitente trasero 1290 Super Duke GT

Trabajos previos

- Quitar el asiento del pasajero (véase el manual de instrucciones).

Montaje

- Desenchufar la clema 7.



- Retirar los tornillos 8.
- Retirar el soporte de matrícula.

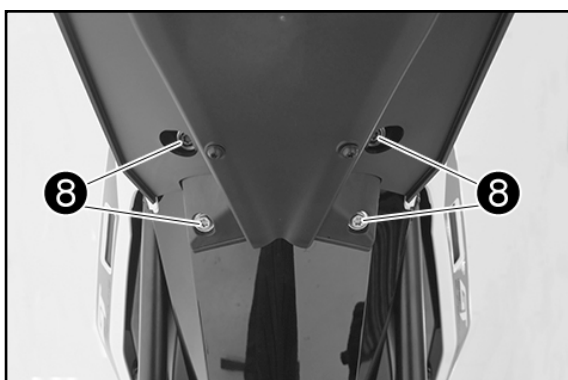

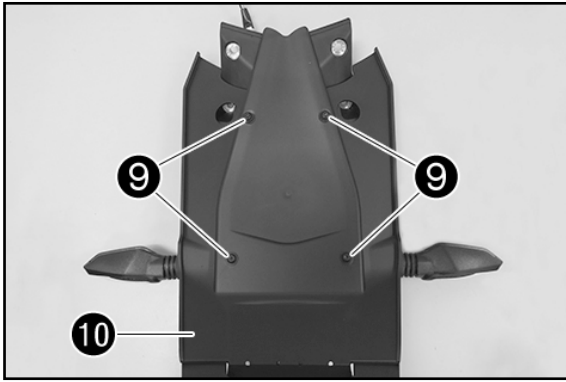

- Retirar los tornillos 9.
- Retirar la tapa 10.

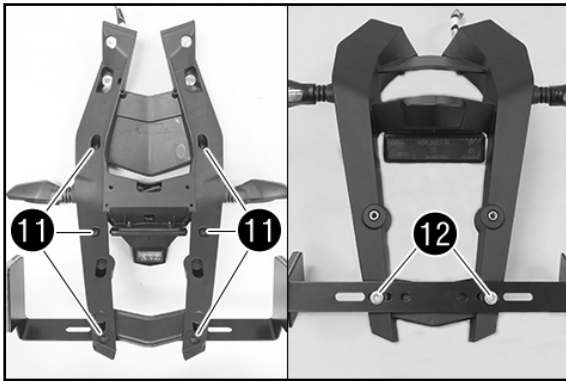

- Retirar los tornillos 11.

Modelos de US:

- Retirar los tornillos 12.
- Retirar los reflectores.

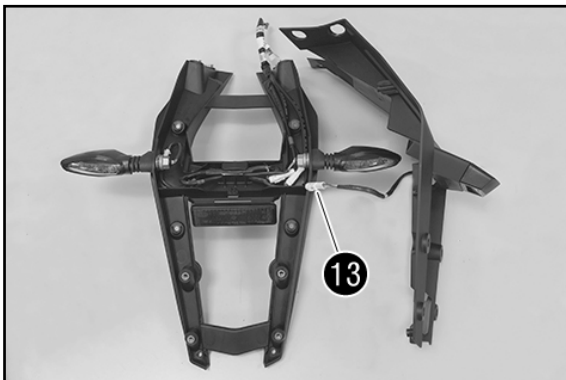

- Quitar la tapa.

- Extraer el cable de la luz de la matrícula y desenchufar la clema 13.
- Retirar la tapa con la luz de la matrícula.

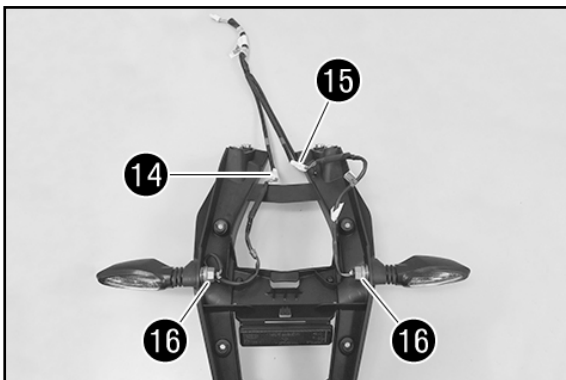

- Dejar todos los cables al descubierto.
- Desenchufar la clema del intermitente izquierdo 14 y derecho 15.
- Soltar completamente las tuercas 16 de la rosca.
- Extraer el intermitente y retirarlo con tuercas y arandelas.

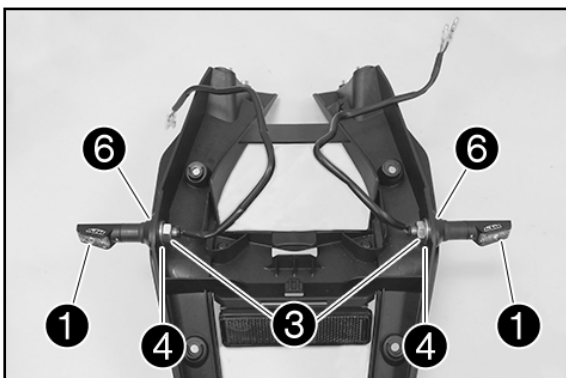

- Premontar el adaptador del intermitente 6 en el intermitente 1 (todo incluido en el volumen de suministro).
- Insertar el intermitente 1 y colocarlo con el adaptador del intermitente 6.
- Montar y apretar las tuercas 3 con las arandelas 4 (todo incluido en el volumen de suministro).

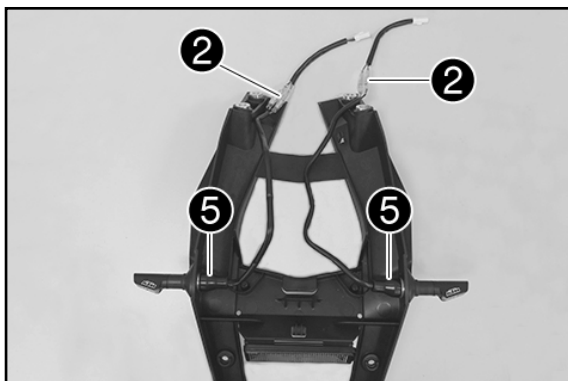

- Montar las cubiertas de protección 5 (volumen de suministro).
- Insertar las resistencias 2 (volumen de suministro) según sus colores.

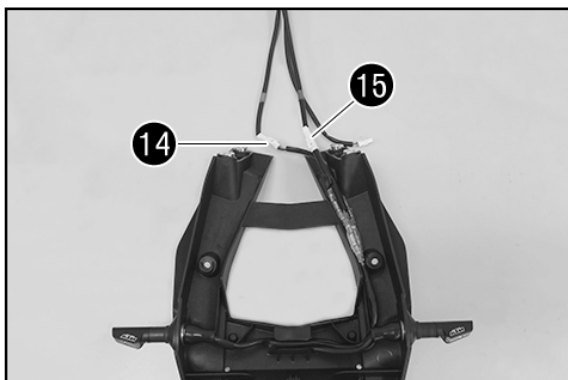

- Tender todos los cables sin tensiones.
- Enchufar la clema del intermitente izquierdo 14 y derecho 15.

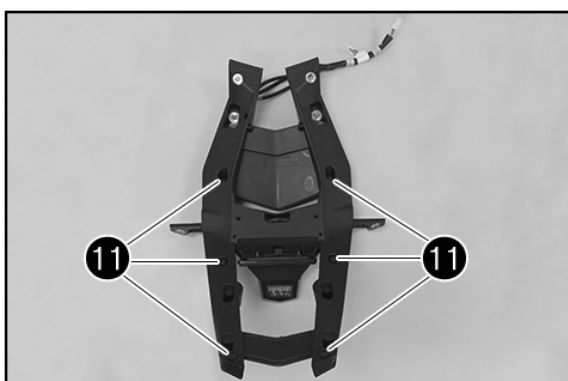

- Enchufar la clema de la luz de la matrícula 13.
- Tender el cable de la luz de la matrícula sin tensiones.
- Colocar la tapa.

! AVISO

¡Asegurarse de que los cables no puedan retorcerse ni quedar aprisionados!

- Montar y apretar los tornillos 11.

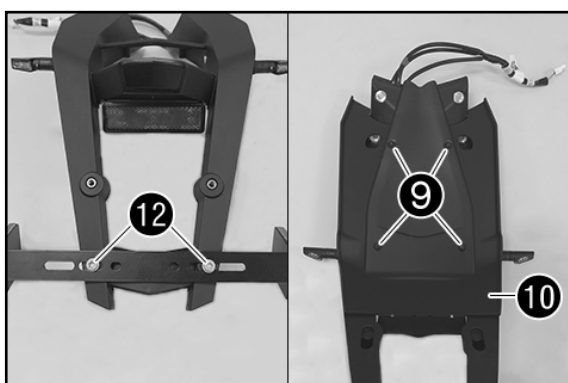

Modelos de US:

- Colocar los reflectores.
- Montar y apretar los tornillos 12.

- Colocar la tapa 10.
- Montar y apretar los tornillos 9.

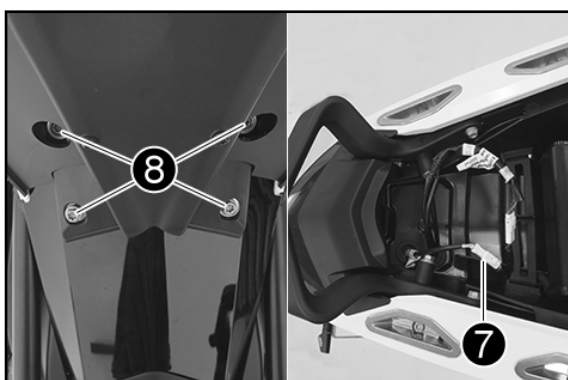

- Colocar el soporte de matrícula y pasar el cable por la parte superior.
- Montar los tornillos 8 y apretarlos a 10 Nm (Loctite 243).
- Enchufar la clema 7.

Trabajos posteriores

- Montar el asiento del pasajero (véase el manual de instrucciones).
- Comprobar el funcionamiento del alumbrado.